

Probing Solutions for Logic Analyzers

Catalog

Create a Quality Connection to Your Target System

To make sure you have the tools for dependable state and timing measurements, no matter what mix of chip packages, test ports and probes your application requires, we've created the largest line of probing solutions in the industry.

Accurate measurements start with reliable probing. Agilent Technologies offers a wide variety of probing accessories to support your measurement needs, making it easy to connect your Agilent logic analyzer to your design.

Each is designed for a specific measurement need because the physical and electrical quality of the connection can mean the difference between a good measurement and a bad one.

About this Document

To assist you in choosing the best state/timing probing solution for your particular target, this document will consider the following:

- Chip packaging, test ports
- Special physical and electrical considerations
- Other accessories and options

Other Reference Documents

Additional information on probing solutions can be found at www.agilent.com/find/logic_analyzer_probes.

For information on probes and accessories for the other related Agilent Technologies logic analysis system products listed below, please refer to "Related Information" in this document:

- Pattern generators

Table of Contents

Reliable Connections	
Ensure Accuracy	2
Which Logic Analyzer?	3
Quick Selection Guide	4
Selecting the Optimum Probing Strategy	5
For All Agilent Logic Analyzers with 40-pin Pod Connectors	5
For All Agilent Logic Analyzers with 90-pin Pod Connectors	7
General-Purpose Probing	8
QFP Package Probing	9
General-Purpose Probing	12
For All Agilent Logic Analyzers with 40-pin Pod Connectors	12
Designing and Probing with Target Connections	15
Normal-Density, Medium-Performance Applications	15
For All Agilent Logic Analyzers with 40-pin Pod Connectors	16
Probing Individual Pins of High-Density Connectors	34
For All Agilent Logic Analyzers with 40-pin Pod Connectors	36
Agilent Logic Analyzers with 90-pin Pod Connectors	41
Agilent 16760A 1.5 Gbits/Sec Logic Analyzer Module	58
Agilent Logic Analyzers with 90-pin Pod Connectors	59
General-Purpose Probing	61
Agilent Logic Analyzers with 90-pin Pod Connectors	61
Agilent 16517A/16518A 1 GHz State / 4 GHz Timing	66
Related Information	68
Support, Services, and Assistance	69

NOTE: Probes are ordered separately. Please specify probes when ordering to ensure the correct connection between your logic analyzer and device under test.



Agilent Technologies

Reliable Connections Ensure Accuracy

- **Impedance**

High input impedance ensures minimum intrusion on your circuit. Although many probes might be acceptable for lower frequencies, capacitive loading becomes significant at higher frequencies. The Agilent Technologies probing products perform over a wide frequency spectrum.

- **Ruggedness**

Probes with quality mechanical design provide solid electrical connections. Intermittent open circuits would only add one more variable to your debugging equation. Agilent probes are mechanically designed to relieve strain and ensure rugged, reliable connection.

- **Immunity to Noise**

Electromagnetic noise can corrupt data captured by the logic analyzer. Agilent probing solutions are designed for a high immunity to transient noise.

- **Performance**

Agilent logic analyzers have front-end circuitry that supports the state and timing specifications of the analyzer. This circuitry, together with the Agilent probing solutions described in this document, will accurately capture the target signals at the specified clock rates.

Signal Frequency Content Drives Probing Solutions

Faster clock rates demand tighter timing tolerances, such as setup and hold specifications. Systems with faster clock rates usually have shorter rise and fall times. Signals with shorter transition times have more high frequency content and are more susceptible to high frequency analog problems such as cross talk, reflections, ground bounce, noise and emissions. Susceptibility of a system to analog problems relates to the transition times of the signals, not the clock rate. A system with slow transition times cannot have high clock rates. However, it is possible for a system with slower clock rates to have signals with very fast transition times.

General-purpose probing solutions provide the analog bandwidth required to run each logic analyzer module at its maximum clock rate. The high input impedance of these probes, especially at high frequencies, presents a minimal load to most systems. Systems that are operating with little margin should be designed with consideration for both the system components and the input impedance of the probing solution being used during debug. Input impedance specifications or equivalent load diagrams can be found for each of the probing solutions described in this document.

Other Considerations

Physical connection compatibility between various Agilent probes may allow you to mix and match a variety of probes and accessories. However, a probe accessory designed for slower clock speeds will not deliver high-speed target performance simply because it is used with a higher speed analyzer module. Also, the serial connection of multiple probe leads and/or accessories will degrade signal integrity.

Which Logic Analyzer?

Agilent logic analyzers have two methods of connection to the probes. One uses a 3M-style connector with 2 rows of 20 pins on 0.1-inch centers, as illustrated in Figure 1.1. Probes for these analyzers are identified in this document as “for analyzers with 40-pin pod connectors.”

The other style uses a 90-pin, high-density connector, as illustrated in Figure 1.2. Probes for these analyzers are identified in this document as “for analyzers with 90-pin pod connectors.”

Currently available Agilent logic analyzers in these two groups are as follows:

40-pin pod connector

16911A

16910A

1680, 1690 series benchtop analyzers

90-pin pod connector

16950A

16760A

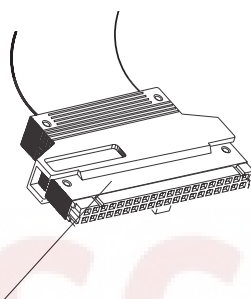


Figure 1.1. 40-pin pod connector

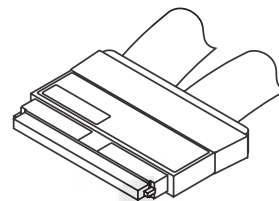


Figure 1.2. 90-pin pod connector



SG Labs
test & measurement instruments

Quick selection guide

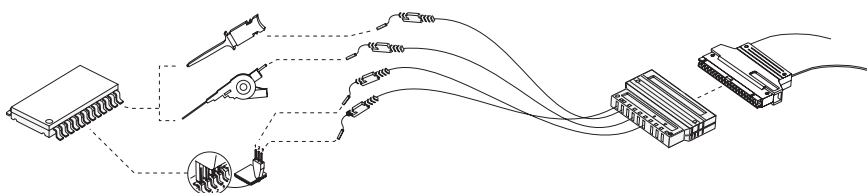
For logic analyzer pod connection	Connection to system under test	Single-ended* or differential	Number of channels	Agilent model number or part number	Page
40-pin	Flying leads	Single-ended	17	E5383A	12
40-pin	Pro Series soft touch	Single-ended	34	E5404A	21
40-pin	Half-size soft touch	Single-ended	17	E5396A	23
40-pin	Soft touch connectorless	Single-ended	34	E5394A	20
40-pin	Samtec connector	Single-ended	34	E5385A	28
40-pin	Mictor connector	Single-ended	34	E5346A	28
40-pin	Mictor connector	Single-ended, low voltage	34	E5339A	28
40-pin	Mictor connector	Single-ended, no isolation networks	34	E5351A	32
90-pin	Flying leads	Single-ended	17	E5382A	61
90-pin	Flying leads	Differential	17	E5381A	64
90-pin	Pro Series soft touch	Differential	17	E5405A	42
90-pin	Pro Series soft touch	Single-ended	34	E5406A	42
90-pin	Half-size soft touch	Single-ended	17	E5398A	52
90-pin	Soft touch connectorless	Single-ended	34	E5390A	43
90-pin	Soft touch connectorless	Differential	17	E5387A	41
90-pin	Samtec connector	Single-ended	34	E5378A	57
90-pin	Samtec connector	Differential	17	E5379A	57
90-pin	Mictor connector	Single-ended	34	E5380A	59

* Isolation networks are included unless designated otherwise.

Selecting the Optimum Probing Strategy

For All Agilent Logic Analyzers with 40-pin Pod Connectors

Connecting to Individual IC Pins or Test Points



Advantages

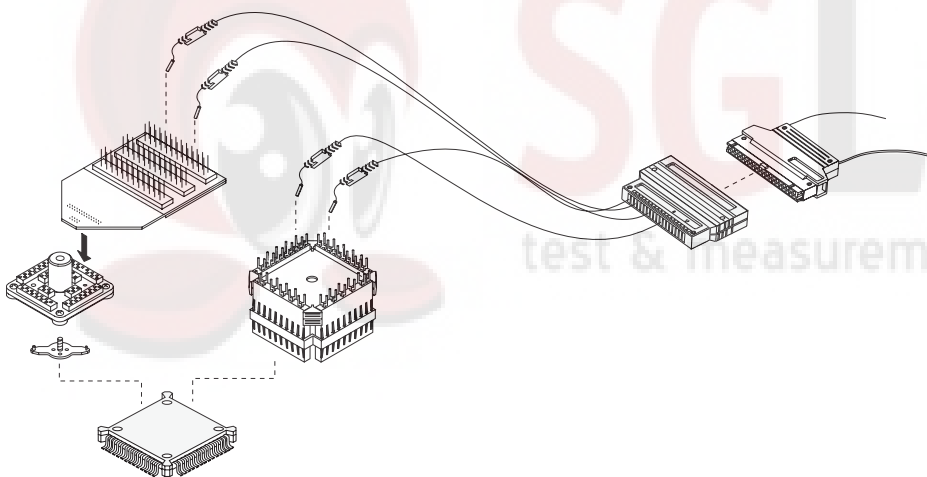
Most flexible method.
Convenient for picking up signals that may not be grouped conveniently on your board with buses routed to connectors (example: system clock, interrupts).

Limitations

Can be time-consuming to connect a large number of channels.
Least space-efficient method.
Some accessories may compromise probe performance.

Go to page 12 for a discussion of Agilent's flying-lead logic analysis probes and accessories for logic analyzers.

Connecting to all the Pins of a Specific Package



Advantages

Rapid access to all pins of fine-pitch QFP package.
Very reliable connections.

Limitations

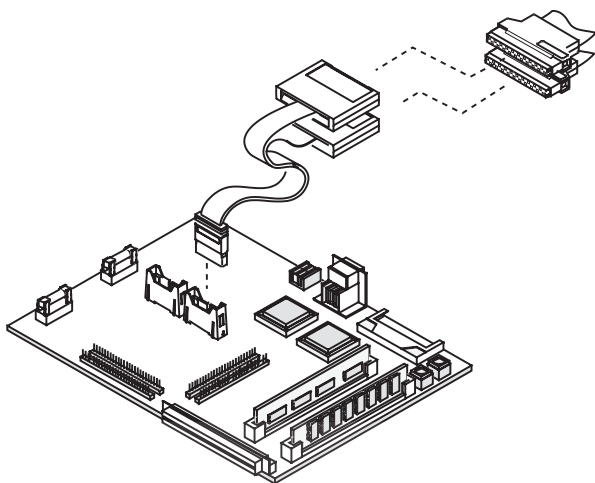
Requires minimal keep-out area.
Requires some time for installation of retainer on IC package.
May compromise probe performance.

Go to page 9 for a discussion of Agilent's QFP package probing solutions for logic analyzers.

Selecting the Optimum Probing Strategy

For All Agilent Logic Analyzers with 40-pin Pod Connectors

Designing Connectors Directly into the Target System



Advantages

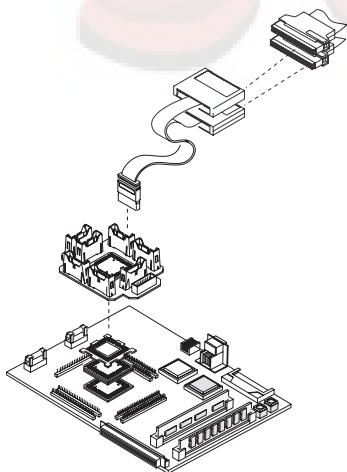
Very reliable connections.
Saves time in making multiple connections.
Least amount of board space required for large number of channels.

Limitations

Requires advanced planning in the design stage.
Requires some dedicated board space.
Moderate incremental cost.

Go to page 16 for a discussion of Agilent's target connector solutions for logic analyzers with 40-pin pod connectors.

Using Processor/Bus Specific Probes



Advantages

Easiest and fastest connections to supported processors and buses.

Limitations

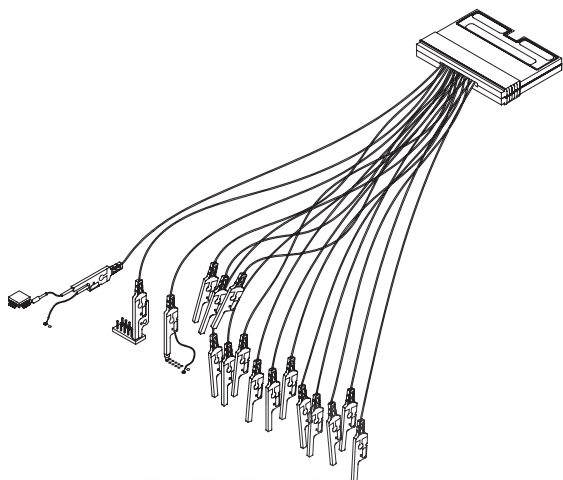
Moderate to significant incremental costs.
Only usable for the specific processor or bus.

Refer to *Processor and Bus Support for Agilent Technologies Logic Analyzers*, publication number 5966-4365E at: <http://www.agilent.com/find/pnbs>
That document will tell you what additional probing accessories you need to connect logic analyzers with 40-pin pod connectors to the analysis probes.

Selecting the Optimum Probing Strategy

For all Agilent Logic Analyzers with 90-pin Pod Connectors

Connecting to Individual IC Pins, Test Points, Browsing or Solder Attach to Components, Traces or VIAs



Advantages

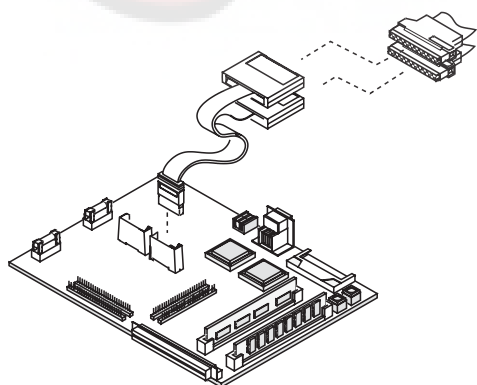
Most flexible method.
Convenient for picking up signals that may not be grouped conveniently on your board with buses routed to connectors (example: system clock, interrupts).

Limitations

Time-consuming to connect large number of channels.
Requires more board space, for large number of channels.
Some accessories may degrade probe performance at high speeds.

Go to page 61-65 for a discussion of Agilent's flying lead probe sets for logic analyzers with 90-pin pod connectors.

Designing Connections Directly into the Target System



Advantages

Very reliable connections.
Save time in making multiple connections.
Least amount of board space required for large number of channels.

Limitations

Requires advanced planning in the design stage.

Go to page 54 for the target connection probing solutions for logic analyzers with 90-pin pod connectors. Go to page 41 for connectorless solutions for logic analyzers with 90-pin pod connectors.

General-Purpose Probing

Wedge Adapters

The Agilent Technologies Wedge technology provides very reliable probing of a few channels on 0.5 mm and 0.65 mm pitch QFPs. No clear area is required around the device. Each Wedge of the probe slides between the legs of the QFP. The side of each Wedge probe contacts the package legs. An insulation core electrically isolates the sides of each Wedge (see Figures 2.1 and 2.2). Various 3-signal, 8-signal, and 16-signal probes are available (see Table 1).

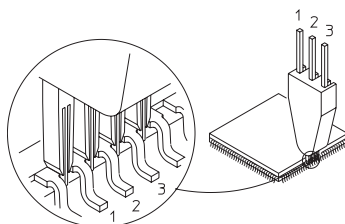


Figure 2.1. Three-signal Wedge electrical connection

IC Leg Spacing	Number of Signals	Number of Wedges in Pack	Model Number
0.5 mm	3	1	E2613A
0.5 mm	3	2	E2613B
0.5 mm	8	1	E2614A
0.5 mm	16	1	E2643A
0.65 mm	3	1	E2615A
0.65 mm	3	2	E2615B
0.65 mm	8	1	E2616A
0.65 mm	16	1	E2644A

Table 1. Wedge probe adapter

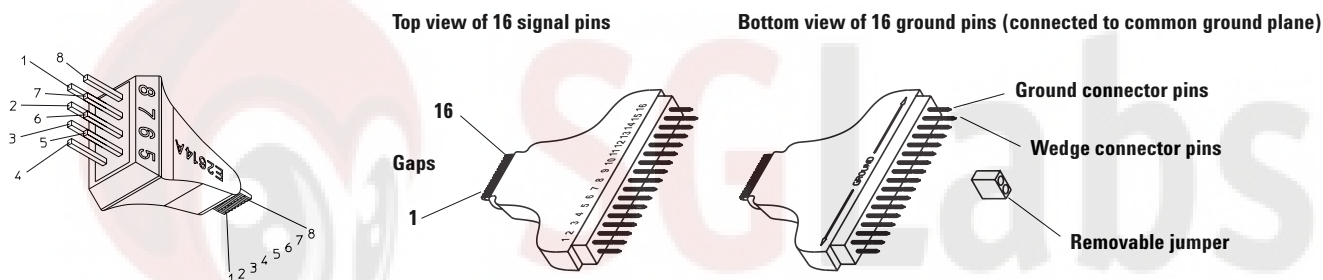


Figure 2.2. Eight-signal and 16-signal Wedge (16-signal Wedge has a common ground plane)

Miscellaneous Probing Accessories

The ferrite core assembly can be added to the probe cable to suppress EMI and RFI noise that can corrupt the measurement.

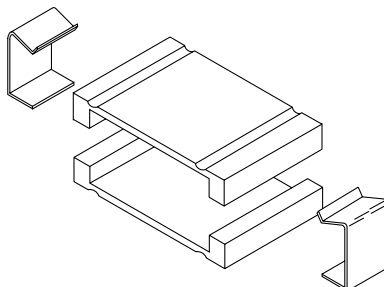


Figure 2.3. Ferrite core assembly, 16555-60001

QFP Package Probing

If your target contains ASICs, FPGAs, or other devices in an industry-standard QFP configuration, Agilent Technologies has a series of elastomeric probes from which you can choose. Agilent's state-of-the-art elastomeric probing technology offers an inexpensive, convenient, and reliable solution for 0.5 mm and 0.65 mm high-density TQFP/CQFP/PQFP packages.

The elastomer material on the probe makes contact between the probe and the pins of a device. Embedded on the surface of the elastomer are redundant connections for each pin, which ensure a reliable and rugged connection.

A locator tool, included with the probe adapter, correctly aligns the retainer to the device. A small amount of adhesive on the bottom of the retainer holds the retainer firmly to the device. After the adhesive is set, the locator tool can be removed. The elastomeric probe adapter then attaches to the device, held in place by the retainer and its knurled nut. Five retainers, a locator tool, and adhesive are included with each elastomeric probe adapter.

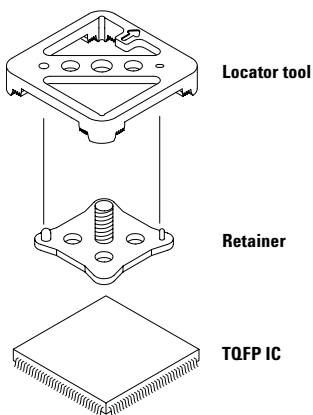


Figure 3.1. Locator tool aligning retainer on the device

Additional Accessories

Quarter flex adapters, shown in Figure 3.2, are available to bring the signals from the elastomeric probe adapter to general-purpose headers for easy connection to logic analyzers, oscilloscopes, or other test equipment. Four 1/4 flex adapters are required to view all signals on a device. Each 1/4 flex adapter provides

connections to the pins on its respective side of the QFP device. Additional retainers and locator tools are also available. A kit of five retainers and adhesive is available as option #201. The locator tool is option #202. These option numbers apply to any of the listed elastomeric probe adapter model numbers, for example, Agilent E5374A #202.

Package	Pin Pitch	Elastomeric Probe Adapter	1/4 Flex Adapter
144-pin TQFP	0.5 mm	E5336A	E5340A
144-pin PQFP/CQFP	0.65 mm	E5361A	E5340A
160-pin PQFP/CQFP	0.65 mm	E5373A	E5349A
160-pin TQFP	0.5 mm	E5377A	E5349A
176-pin TQFP	0.5 mm	E5348A	E5349A
208-pin PQFP/CQFP	0.5 mm	E5374A	E5371A
240-pin PQFP/CQFP	0.5 mm	E5363A	E5371A

Table 2. Elastomeric probe adapters

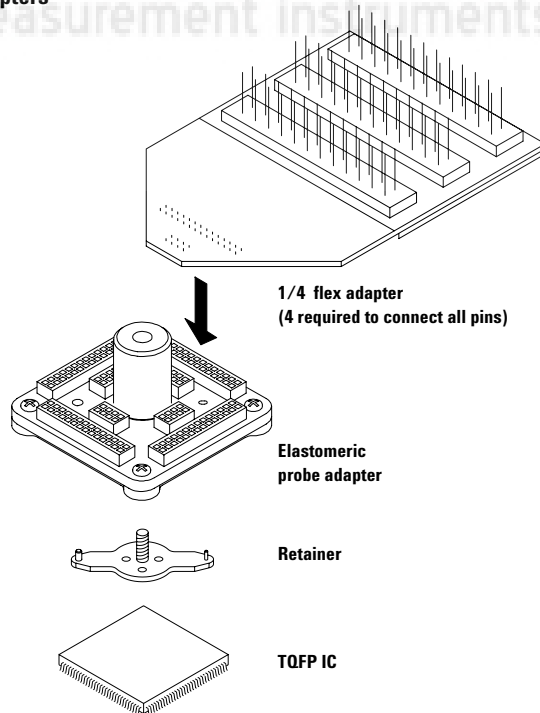


Figure 3.2. Elastomeric probing solution

QFP Package Probing

Electrical characteristics for this probing technology are listed in Table 3.

Note: The Agilent logic analyzer probes are connected to the adapters shown in this section. The target system impedance load is increased slightly (see Table 3). Fast transition times (< 2 - 3 ns) may suffer some loss of signal fidelity.

The probe adapters require a minimal “keep out” area around the device, as shown in the dimension tables of Figures 3.3 and 3.4.

Electrical Characteristics	Elastomeric Probe Adapter	1/4 Flex Adapter
Operating voltage	<40 V (DC + peak AC)	<40 V (DC + peak AC)
Operating current	0.5A (max)	0.5A (max)
Insulation resistance	>100 MΩ	>100 MΩ

Model Parameters

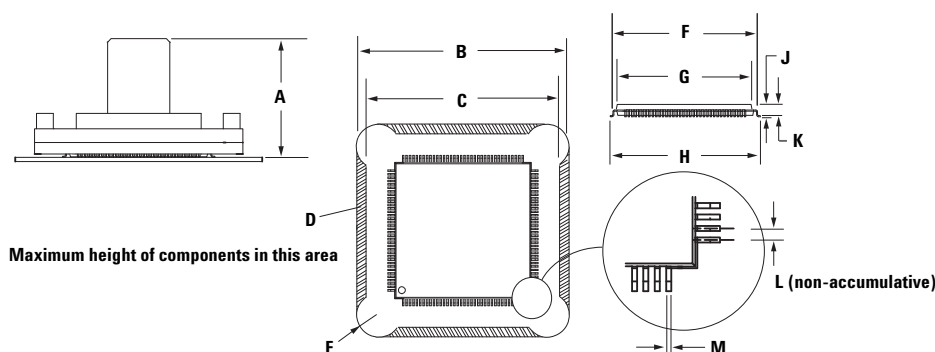
Pin-to-ground plane capacitance (typical)		E5340A 3.0 pF first row 4.0 pF second row 6.0 pF third row
		E5349A 2.5 pF first row 3.5 pF second row 5.0 pF third row
		E5371A 2.5 pF first row 3.5 pF second row 5.0 pF third row
Pin-to-pin capacitance	0.5 pF	2 pF
Self inductance (typical)		E5340A 15 nH first row 25 nH second row 35 nH third row
		E5349A 20 nH first row 30 nH second row 40 nH third row
		E5371A 20 nH first row 30 nH second row 40 nH third row

Environmental Characteristics

Operating temperature	0°C to 50°C	0°C to 50°C
Maximum operating humidity	75% relative humidity	75% relative humidity

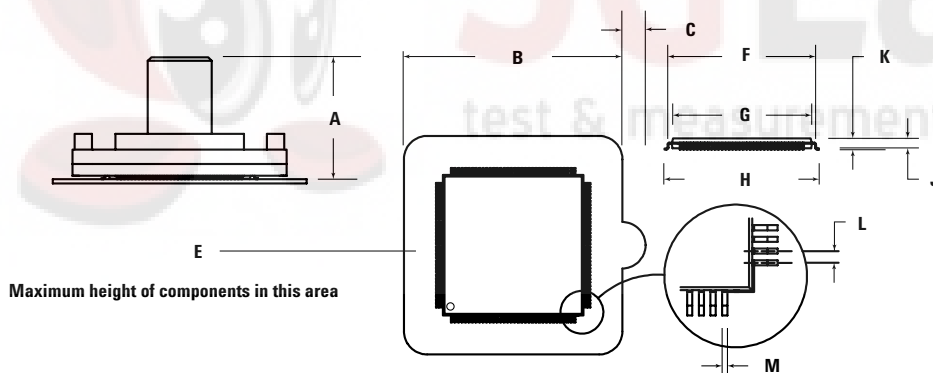
Table 3. Probe and flexible adapter electrical and environmental characteristics

QFP Package Probing



Adapter	A	B	C	D	E	F	G	H	J	K	L	M
144-Pin TQFP												
(inches)	0.674	1.240	1.130	0.055	0.138	0.827 (min)	0.795 (max)	0.866±0.008	0.057 to 0.063	0.053 to 0.057	0.0197±0.0012	0.009±0.002
(millimeters)	17.13	31.50	28.70	1.40	3.50	21.00 (min)	20.20 (max)	22.00±0.20	1.450 to 1.60	1.350 to 1.45	0.500±0.03	0.220±0.05
160-Pin TQFP												
(inches)	0.76	1.343	1.343	0	0.11	0.988 (min)	0.953 (max)	1.024±0.008	0.061 to 0.063	0.051 to 0.059	0.01965±0.001	0.0087 to 0.015
(millimeters)	19.2	34.11	34.11	0	2.79	25.09 (min)	24.20 (max)	26.00±0.20	1.550 to 1.61	1.3 to 1.5	0.50±0.03	0.220 to 0.38
176-Pin TQFP												
(inches)	0.674	1.398	1.287	0.055	0.138	0.984 (min)	0.953 (max)	1.024±0.008	0.057 to 0.063	0.053 to 0.057	0.0197±0.0012	0.009±0.002
(millimeters)	17.13	35.50	32.70	1.40	3.50	25.00 (min)	24.20 (max)	26.00±0.20	1.450 to 1.60	1.350 to 1.45	0.50±0.03	0.220±0.05

Figure 3.3. Elastomeric probe and package dimensions for TQFP



Adapter	A	B	C	E	F	G	H	J	K	L	M
144-Pin PQFP/CQFP											
(inches)	0.73	1.583	0.16	0.01	1.135 (min)	1.106 (max)	1.236 (max)	0.094 to 0.098	0.108 (max)	.0256±0.0012	0.009±0.002
(millimeters)	18.5	40.21	4	0.3	28.85 (min)	28.10 (max)	31.40 (max)	2.40 to 2.50	2.75 (max)	0.65±.03	0.22±0.05
160-Pin PQFP/CQFP											
(inches)	0.76	1.583	0.16	0.03	1.154 (min)	1.106 (max)	1.266 (max)	0.126 to 0.146	0.136 to 0.161	.0256±0.0012	0.009±0.002
(millimeters)	19.2	40.21	4	0.8	29.32 (min)	28.10 (max)	32.15 (max)	3.20 to 3.70	3.45 to 4.10	0.65±.03	0.22±0.05
208-Pin PQFP/CQFP											
(inches)	0.76	1.583	0.16	0.03	1.136 (min)	1.110 (max)	1.197 to 1.213	0.126 to 0.142	0.136 to 0.161	0.0197±0.0012	0.009±0.002
(millimeters)	19.2	40.21	4	0.8	28.85 (min)	28.20 (max)	30.40 to 30.80	3.20 to 3.60	3.45 to 3.60	0.50±0.03	0.22±0.05
240-Pin PQFP/CQFP											
(inches)	0.76	1.937	0.16	0.03	1.293 (min)	1.268 (max)	1.354 to 1.370	0.126 to 0.142	0.136 to 0.161	0.0197±0.0012	0.009±0.002
(millimeters)	19.2	49.20	4	0.8	32.85 (min)	32.20 (max)	34.40 to 34.80	3.20 to 3.60	3.45 to 3.60	0.50±0.03	0.22±0.05

Figure 3.4. Elastomeric probe and package dimensions for PQFP/CQFP

General-Purpose Probing

For All Agilent Logic Analyzers with 40-pin Pod Connectors

E5383A 17-Channel Single-Ended Flying Lead Probe

Ideal when only a few lines may need to be probed or probe points are distributed across a target. The E5383A includes a set of 20 IC test clips and five ground leads.

Logic Analysis General-Purpose Probes

General-purpose probing requires connecting probe leads to individual signal lines. This method is most convenient for a small to moderate number of signals, very flexible, and can be used in conjunction with other probing methods.

Note: Any probed signal line must be able to supply a minimum of 600 mV to the probe with the specified loading.

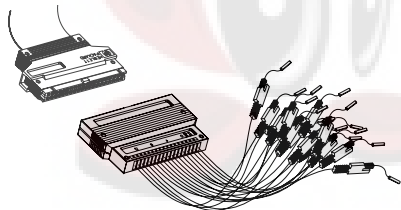


Figure 4.2. E5383A 17-channel probe lead set

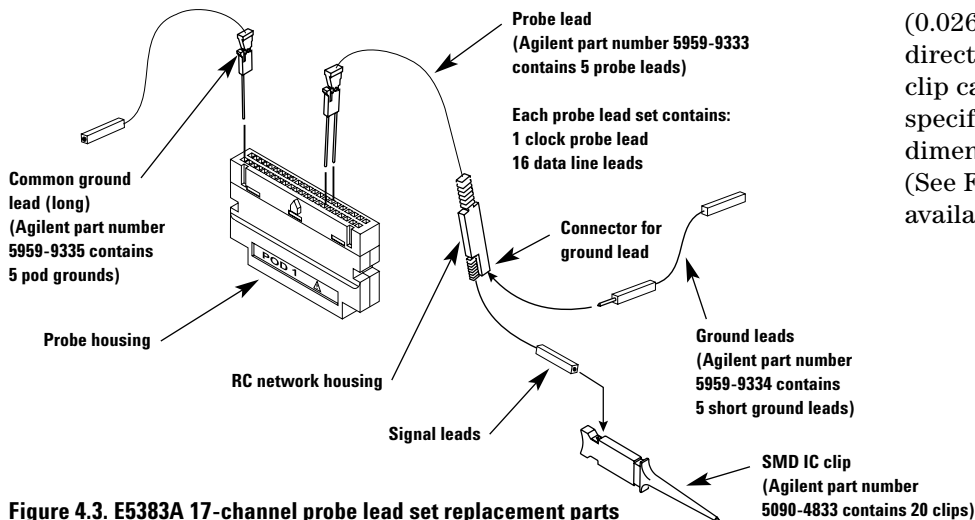


Figure 4.3. E5383A 17-channel probe lead set replacement parts

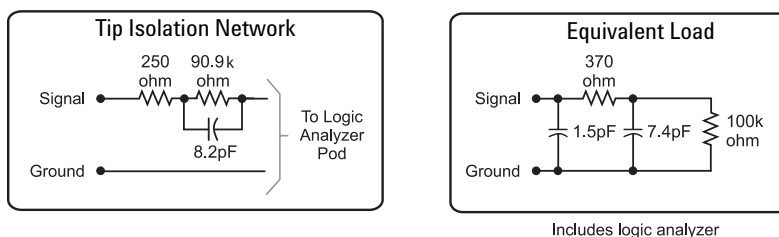


Figure 4.1. Probe tip isolation network and equivalent load

The Standard Probing System

The standard probing system consists of IC clips, probe leads, probe housing and probe cable. Because it is passive, the standard probing system is smaller, lighter, and much easier to use than active probing systems. This passive probing system is similar to a probing system used on a high frequency oscilloscope. It consists of an isolation network (as shown in Figure 4.1) at the probe tip and a shielded resistive transmission line. The advantages of this system are:

- High input impedance. See Figure 4.1.
- Signal ground at the probe tip for high-speed signals.
- Inexpensive, removable probe tip assemblies.

Probe Leads and Lead Sets

Probe leads are configured into lead sets, which can probe 16 data channels with ground, one clock channel, and a common ground. A 17-channel probe lead set (E5383A) is shown in Figure 4.2, along with the replacement part numbers for individual components in Figure 4.3.

Each probe lead is a 12-inch, twisted-pair cable connected to the probe cable at the probe housing (see Figure 4.3). The probe tip includes a signal lead, a connector for a ground lead, and the isolation network.

The signal and ground leads can be connected directly to the target system. This requires installing 0.63 mm (0.025 in) square pins, or round pins with a diameter of between 0.66 mm (0.026 in) and 0.84 mm (0.033 in) directly on the board. An IC test clip can also be used. The same specifications apply for the pin dimensions of the test clip. (See Figure 4.6 for IC test clips available from Agilent.)

General-Purpose Probing

For All Agilent Logic Analyzers with 40-pin Pod Connectors

IC Clips

The surface-mount device IC clip with twin hooks (part number 5090-4833, containing 20 IC clips) is designed for fine surface-mounted component leads. The twin hook 0.5 mm IC clip (part number 10467-68701, containing four 0.5 mm IC clips), is very useful for 0.5 mm pitch components. See Figure 4.5.

The E2421A kit contains one each: 8-pin, 14-pin, 16-pin, 20-pin, 24-pin, and 28-pin SOIC test clips. See Figure 4.6.

The E2422A kit contains one each: 20-pin, 28-pin, 44-pin, 52-pin, 66-pin, and 84-pin QUAD IC test adapters. See Figure 4.6.

Grounding

There are three methods of grounding the probe system. First, the entire probe lead set can be grounded through the common ground. This requires only one connection, but is not recommended because it will cause poor signal fidelity in systems with fast transition times. The recommended method is to individually ground each probe lead. This yields optimal signal fidelity and is required for signals with faster transition times ($< 4 - 5$ ns).

For moderate rise times (greater than 2 ns), it may be acceptable to ground every other (or every fourth) ground connection to the target.

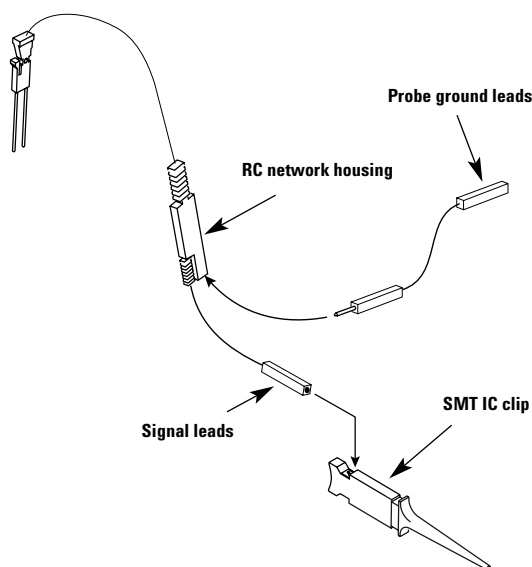


Figure 4.4. Connecting IC clips and ground leads to probes

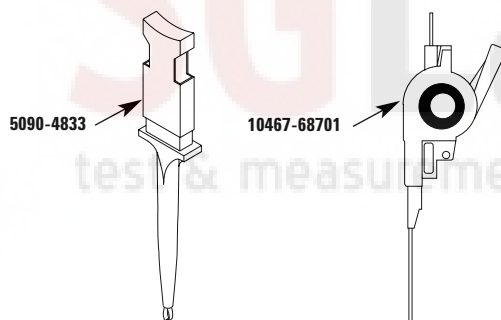


Figure 4.5. SMD IC clip and 0.5 mm IC clip

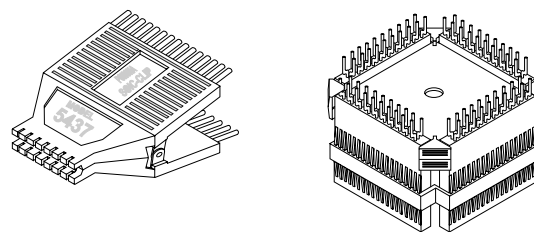


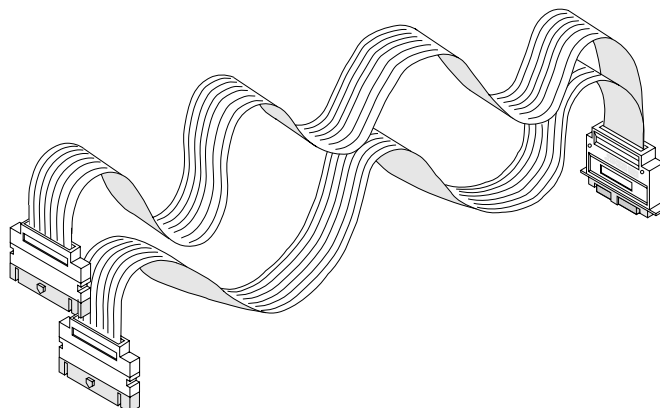
Figure 4.6. Typical IC test clips available in E2421A SOIC kit (left) and E2422A QUAD kit (right)

General-Purpose Probing

For All Agilent Logic Analyzers with 40-pin Pod Connectors

Signal Line Loading

Any probed signal line must be able to supply a minimum of 600 mV (unless noted otherwise – see probe of interest) to the probe tip while the probe is connected to the system. The maximum input voltage of each probe is ± 40 volts peak (unless noted otherwise – see probe of interest).



Probe Cables

The probe cable (see Figure 4.7 and Table 4) contains 16 signal lines and two clk lines, two +5 volt power lines, and ground lines for each of the signal/clock and power lines. All of these lines are contained in a 4.5-foot cable. The probe cable is included with the logic analyzer. The cable grounds are chassis (earth) grounds, not “floating” grounds. The two +5 volt power lines can be used to power active probing systems. Consult the specifications for the individual logic analyzers or logic analyzer cards for the maximum allowable current through each +5 volt power supply.

Caution: These +5 volt power lines MUST NOT be connected to the target’s power supply.

Caution: Be careful when using straight wire probe leads, one common ground, or RC networks located far from the target. These circumstances increase the impact of analog effects such as crosstalk and EMT susceptibility, which contribute to measurement errors.

Figure 4.7. Logic analyzer probe cable

Logic Analyzer Stand Alone or Module	01660-61605	16555-61606	16710-61603	16715-61601
16550A	x			
16554A		x		
16555A/D		x		
16556A/D		x		
16557D			x	
16710A			x	
16711A			x	
16712A			x	
16715A				x
16716A				x
16717A				x
16718A				x
16719A				x
16740 Series				x
16750A/B				x
16751A/B				x
16752A/B				x
16910A				x
16911A				x
1670 Series			x	
1680 Series				x
1690 Series				x

Table 4. Probe cables supplied with Agilent logic analyzers

Designing and Probing with Target Connections Normal-Density, Medium-Performance Applications

In some cases, you may not have a standard QFP package on the target available for probing access, or your device may be available only in BGA packaging.

Agilent recommends that targets with probing constraints have connectors designed into the prototype versions of the product for effective hardware and software debug. The following should be considered when designing with connectors:

- Select the appropriate connector technology for your target speed and target density.
- Carefully select all lines for routing to the connectors that may be needed for debug.
- Group the lines at each connector for your probing convenience. For example, Agilent may have written an inverse assembler for your device that has a preconfigured signal order. Before designing, refer to the documentation for this inverse assembler for essential signal lines and order.
- Keep the routing to connectors as short as possible to minimize target impact and provide accurate data.
- Examine the impact of probing isolation networks designed into the target vs. the isolation network products offered by Agilent Technologies.

An isolation network must be located between the target and the logic analyzer. It can be located on the target board in through-hole or SMT parts; or it can be attached to the logic analyzer cable with the probe leads (the isolation network is molded into the end of the probe); or the Agilent 01650-63203 isolation adapter with self contained isolation networks can be used. Probe leads can be used with connectors but are not the most convenient method. Direct connection of the connectors with the analyzer cable (isolation network parts on the target) or with a probe or isolation adapter is the faster, more convenient method.

SG Labs
test & measurement instruments

Designing and Probing with Target Connections

For All Agilent Logic Analyzers with 40-pin Pod Connectors

High-Density, High-Performance Probes

Agilent Pro Series Soft Touch Connectorless Logic Analyzer Probes

Agilent Technologies has developed connectorless logic analyzer probes based on soft touch probing technology. Connectorless logic analyzer probing removes the connector that is traditionally attached to the target board and replaces it with an array of probe pads. This reduces the probe load on the target by eliminating the loading associated with the physical body of the connector. Additionally, this streamlines the design flow by eliminating the need to assign a logic analyzer connector to the bill of material of your board, procuring those connectors and then having them loaded onto your board.

Agilent's soft touch connectorless probes use micro spring-pin technology to provide reliable contact which is not dependent on the planarity of the PC board or the

plating processes used to fabricate the board. No special cleaning processes are required when using Agilent's soft touch probes.

The new Agilent Technologies Pro Series soft touch connectorless probes offer a 30% smaller footprint than the original soft touch probes and are the basis for the industry standard connectorless probing footprint.

The probes use a retention module that ensures soft touch pin-to-PC board pad alignment and holds the probe in place while in use. The Pro Series soft touch uses a "top-side" mountable retention module. The retention module is mounted on the same side of the board as the probing footprint so there is no need to access the back-side of the board. Because there is no requirement for the retention module pins to extend beyond the back-side of the board, the retention module is compatible with virtually any board thickness.

E5404A Pro Series Soft Touch Connectorless Probe

The E5404A is a 34-channel single-ended Pro Series soft touch connectorless probe compatible with all Agilent logic analyzers that have a 40-pin pod connector. It is capable of acquiring data at the maximum rates of the logic analyzer it is connected to.

Features

- No connector on the target board
- Top-side mount retention module
- Industry-standard connectorless footprint
- 34 channels, single-ended clock and data
- Extremely low, <0.7 pF, equivalent load capacitance
- Capable of data rates >2.5 Gb/s (maximum rate dependent on analyzer used)
- 500 mV p-p minimum signal amplitude
- Robust and reliable soft touch technology

Unused clock inputs can be used as data inputs.

The E5404A (used with logic analyzers with a 40-pin cable connector) uses the same footprint, pinout, and retention module as the E5406A Pro Series soft touch connectorless probe (used with logic analyzers with a 90-pin cable connector).

A kit of five retention modules is shipped with each Pro Series soft touch probe. Additional kits can be ordered using Agilent part number E5403A.

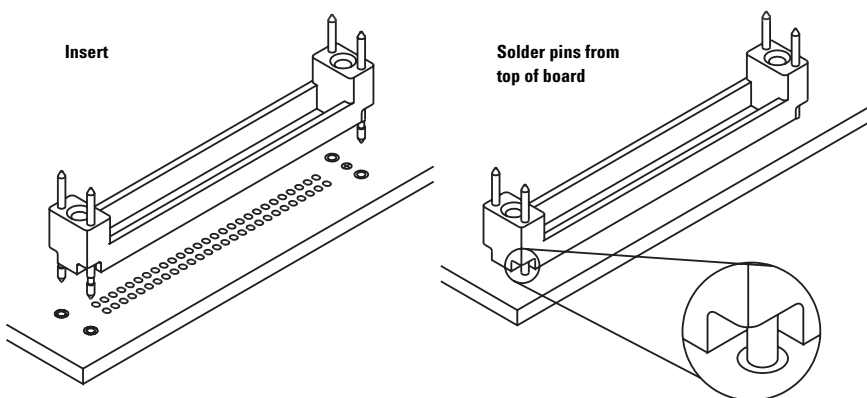


Figure 5.1. "Top-side" mountable retention module.

Designing and Probing with Target Connections

For All Agilent Logic Analyzers with 40-pin Pod Connectors

E5394A Soft Touch Connectorless Probe

The E5394A is a 34-channel single-ended soft touch connectorless probe compatible with all Agilent logic analyzers that have a 40-pin pod connector. It is capable of acquiring data at the maximum rates of the logic analyzer it is connected to. The probe has the following inputs:

- 32 single-ended data inputs
- two single-ended clock inputs
- < 0.7 pf input capacitance
- 500 mV p-p minimum signal amplitude

Unused clock inputs can be used as data inputs.

The E5394A (used with logic analyzers with a 40-pin pod connector) uses the same footprint, pinout and retention module as the E5390A single-ended soft touch connectorless probe (used with logic analyzers with a 90-pin pod connector).

A kit of five retention modules is shipped with each soft touch probe. Additional kits can be ordered using Agilent part number E5387-68701.

E5396A Half-Size Soft Touch Connectorless Probe

The E5396A is a small space saving probe compatible with all Agilent logic analyzers that have a 40-pin cable connector. It is a 17-channel, single-ended probe capable of capturing data at the maximum rates of the logic analyzer it is connected to. The probe has the following inputs:

- 16 single-ended data inputs
- one single-ended clock input
- <0.7 pf equivalent load capacitance
- 500 mV p-p minimum signal amplitude

The unused clock input can be used as a data input.

The E5396A (used with logic analyzers with a 40-pin cable connector) uses the same footprint, pinout, and retention module as the E5398A single-ended soft touch connectorless probe (used with logic analyzers with a 90-pin cable connector).

More information about soft touch connectorless probes is available on the web at www.agilent.com/find/softtouch.

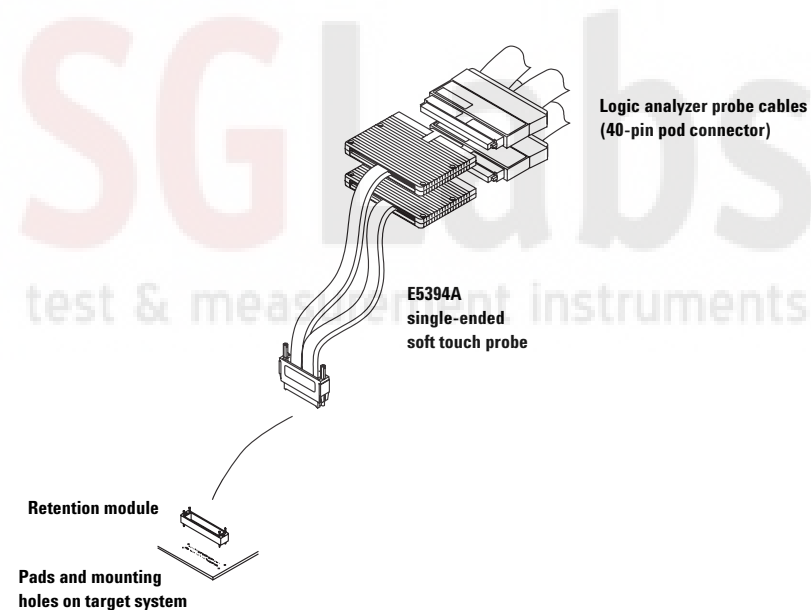


Figure 5.2. Agilent E5394A soft touch probe connection

Designing and Probing with Target Connections

For All Agilent Logic Analyzers with 40-pin Pod Connectors

Probe Dimensions

The following figures show dimensions, footprint, and pinout information you will need to design your target system board for use with the Agilent Pro Series soft touch probes.

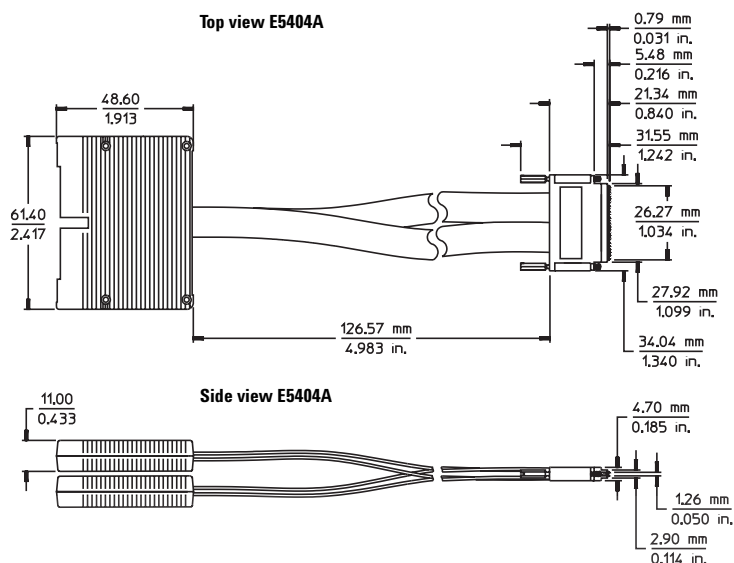


Figure 5.3. E5404A probe dimensions

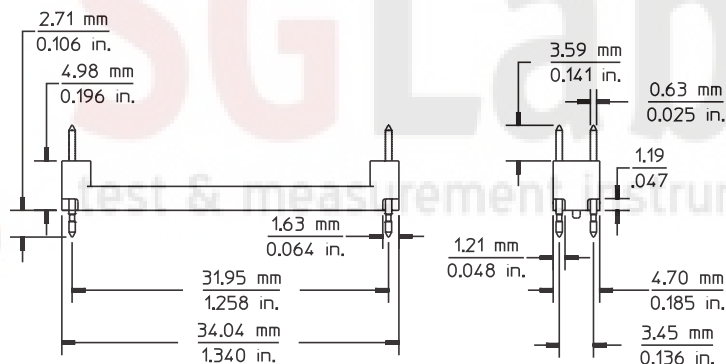


Figure 5.4. Pro Series soft touch retention module dimensions

Probe and Retention Module Dimensions

The following dimensions show the Pro Series soft touch probe attached to the retention module. The retention module is mounted on the PC board.

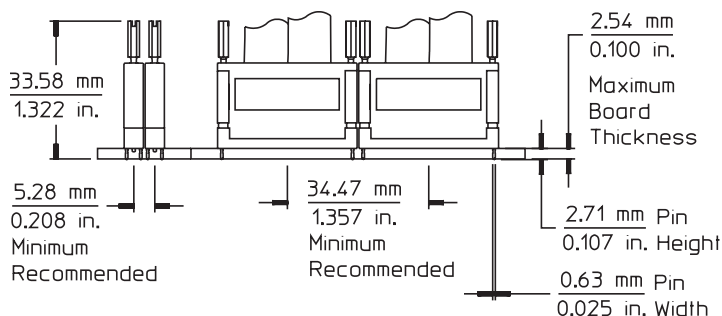


Figure 5.5. Pro Series soft touch side-by-side dimensions

Designing and Probing with Target Connections

For All Agilent Logic Analyzers with 40-pin Pod Connectors

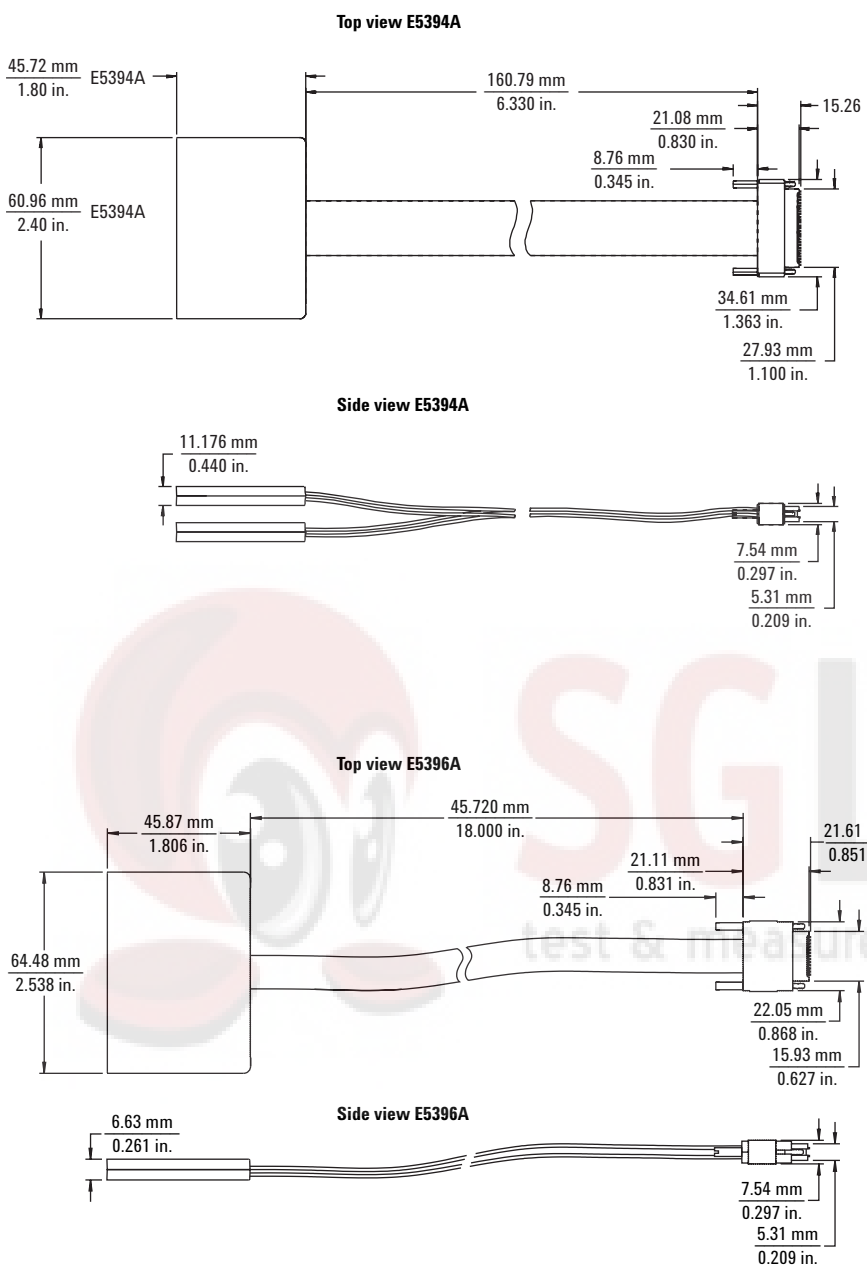


Figure 5.6. E5394A and E5396A soft touch probe dimensions

Designing and Probing with Target Connections

For All Agilent Logic Analyzers with 40-pin Pod Connectors

Retention Module Dimensions

The soft touch probes are attached to the PC board using a retention module which ensures pin-to-pad alignment and holds the probe in place. A board thickness of up to 2.54 mm (0.100 in.) is recommended. Insert the retention module into the board, noting the keying pin, and solder the four alignment pins to the backside of the board.

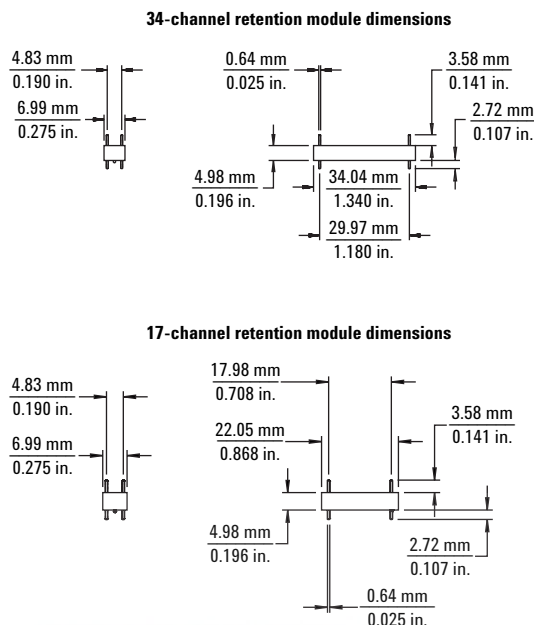


Figure 5.7. Retention module dimensions

Probe and Retention Module Dimensions

The following dimensions show the soft touch probe attached to the retention module. The retention module is mounted on the PC board.

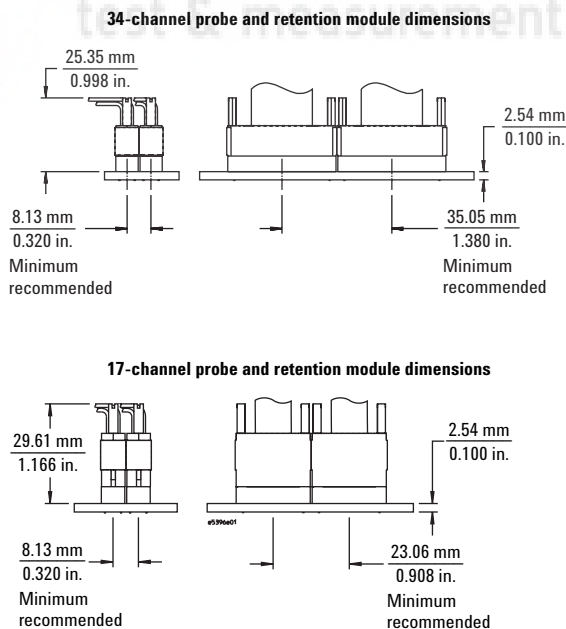
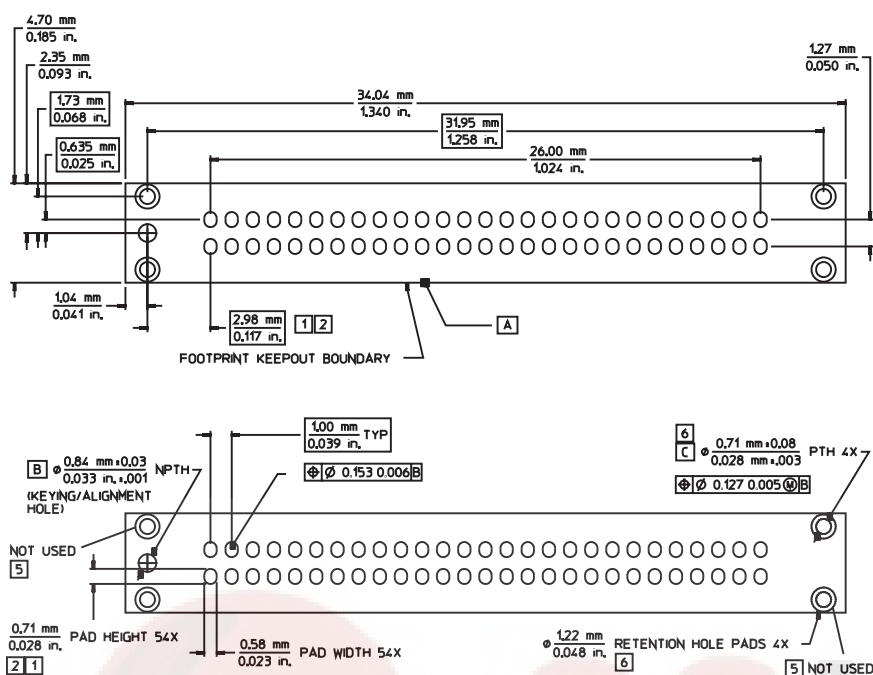


Figure 5.8. Side-by-side dimensions

Designing and Probing with Target Connections

For All Agilent Logic Analyzers with 40-pin Pod Connectors



Drawing notes:

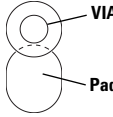
- 1 Maintain a solder mask web between pads when traces are routed between the pads on the same layer. The solder mask may not encroach onto the pads within the pad dimension shown.
- 2 VIAs not allowed on these pads. VIA edges may be tangent to pad edges as long as a solder mask web between VIAs and pads is maintained. 
- 3 Surface finishes on pads should be HASL immersion silver, or gold over nickel.
- 4 This footprint is compatible with retention module Agilent part number E5405-68702.
- 5 This through hole is not used with the Agilent retention module.
- 6 Plated through hole should not be tied to ground plane for thermal relief.

Figure 5.9. Pro Series soft touch footprint dimensions (see drawing notes).

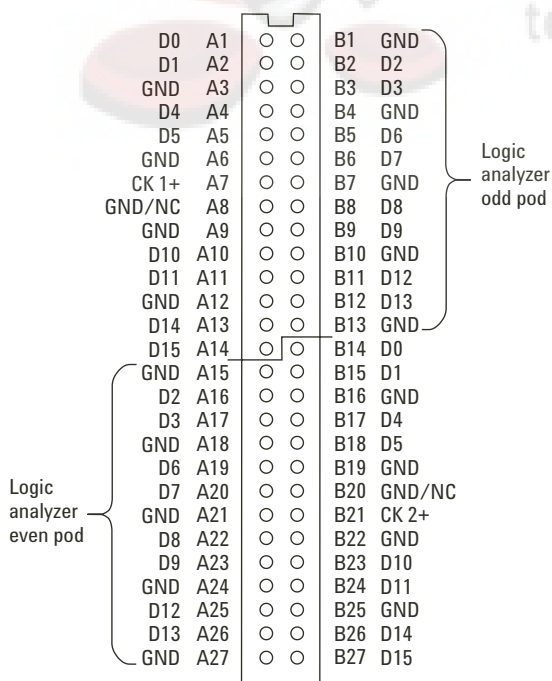


Figure 5.10. Pad numbers for E5404/06A 34-channel single-ended probes.

Designing and Probing with Target Connections

For All Agilent Logic Analyzers with 40-pin Pod Connectors

E5404/06A 34-Channel

Single-Ended Probe

Signal Name	Pad #	Logic Analyzer Channel	Pod
D0	A1	→ 0	Whichever pod is connected to "Odd" on the E5404/06A probe
D1	A2	→ 1	
Ground	A3		
D4	A4	→ 4	
D5	A5	→ 5	
Ground	A6		
Clock 1+	A7	→ Clock	
GND/NC/Clock 1-	A8		
Ground	A9		
D10	A10	→ 10	
D11	A11	→ 11	
Ground	A12		
D14	A13	→ 14	
D15	A14	→ 15	
Ground	A15		
D2	A16	→ 2	
D3	A17	→ 3	
Ground	A18		
D6	A19	→ 6	
D7	A20	→ 7	
Ground	A21		
D8	A22	→ 8	
D9	A23	→ 9	
Ground	A24		
D12	A25	→ 12	
D13	A26	→ 13	
Ground	A27		

E5404/06A 34-Channel

Single-Ended Probe

Signal Name	Pad #	Logic Analyzer Channel	Pod	
Ground	B1		Whichever pod is connected to "Odd" on the E5404/06A probe	
D2	B2	→ 2		
D3	B3	→ 3		
Ground	B4			
D6	B5	→ 6		
D7	B6	→ 7		
Ground	B7			
D8	B8	→ 8		
D9	B9	→ 9		
Ground	B10			
D12	B11	→ 12		
D13	B12	→ 13		
Ground	B13			Whichever pod is connected to "Even" on the E5404/06A probe
D0	B14	→ 0		
D1	B15	→ 1		
Ground	B16			
D4	B17	→ 4		
D5	B18	→ 5		
Ground	B19			
GND/NC/Clock 2-	B20			
Clock 2+	B21	→ Clock		
Ground	B22			
D10	B23	→ 10		
D11	B24	→ 11		
Ground	B25			
D14	B26	→ 14		
D15	B27	→ 15		

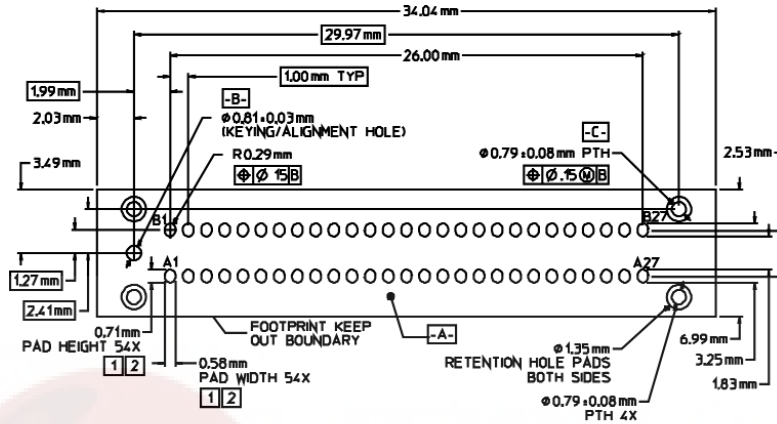
Designing and Probing with Target Connections

For All Agilent Logic Analyzers with 40-pin Pod Connectors

Probe Footprint Dimensions

Use these probe footprint dimensions for the PC board pads and holes for attaching the retention module.

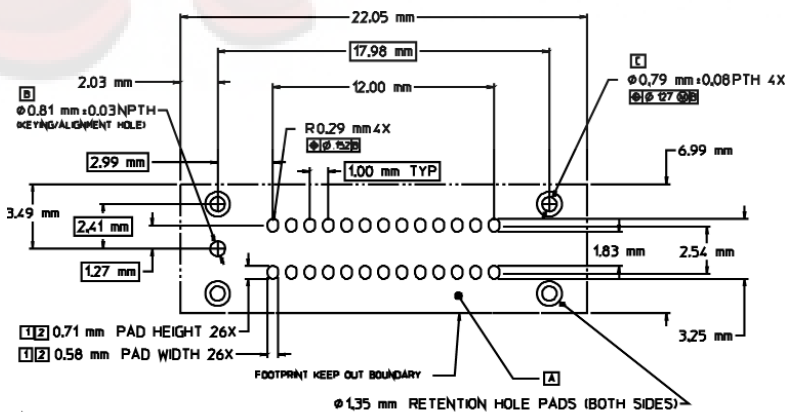
Soft touch



NOTES:

1. MUST MAINTAIN A SOLDER MASK WEB BETWEEN PADS WHEN TRACES ARE ROUTED BETWEEN THE PADS ON THE SAME LAYER. SOLDERMASK MAY NOT ENCR OACH ONTO THE PADS WITHIN THE PAD DIMENSION SHOWN.
2. VIA IN PAD NOT ALLOWED ON THESE PADS. VIA EDGES MAY BE TANGENT TO PAD EDGES AS LONG AS A SOLDER MASK WEB BETWEEN VIAS AND PADS IS MAINTAINED.
3. PERMISSABLE SURFACE FINISHES ON PADS ARE HASL, IMMERSION SILVER, OR GOLD OVER NICKEL.
4. FOOTPRINT IS COMPATIBLE WITH RETENTION MODULE. AGILENT PART #E5387-68702.
5. RETENTION MODULE DIMENSIONS ARE 34.04 mm x 7.01 mm x 4.98 mm TALL RELATIVE TO THE TOP SURFACE OF THE PDB. RETENTION PINS EXTEND 4.32 mm BEYOND THE BOTTOM SURFACE OF THE RM THROUGH THE PCB.
6. ASSUME NORMAL ARTWORK TOLERANCES FOR PAD SIZE DIMENSIONS

Half-size soft touch



NOTES:

1. MUST MAINTAIN A SOLDER MASK WEB BETWEEN PADS WHEN TRACES ARE ROUTED BETWEEN THE PADS ON THE SAME LAYER. SOLDERMASK MAY NOT ENCR OACH ONTO THE PADS WITHIN THE PAD DIMENSION SHOWN.
2. VIA IN PAD NOT ALLOWED ON THESE PADS. VIA EDGES MAY BE TANGENT TO PAD EDGES AS LONG AS A SOLDER MASK WEB BETWEEN VIAS AND PADS IS MAINTAINED.
3. PERMISSABLE SURFACE FINISHES ON PADS ARE HASL, IMMERSION SILVER, OR GOLD OVER NICKEL.
4. FOOTPRINT IS COMPATIBLE WITH RETENTION MODULE. AGILENT PART NUMBER E5396-68702.
5. RETENTION MODULE DIMENSIONS ARE 20.04 mm x 6.99 mm x 4.95 mm TALL RELATIVE TO THE TOP SURFACE OF THE PCB. RETENTION PINS EXTEND 27.48 mm BEYOND THE BOTTOM SURFACE OF THE RM THROUGH THE PCB.

Figure 5.11. Footprint dimensions

Designing and Probing with Target Connections

For All Agilent Logic Analyzers with 40-pin Pod Connectors

Pinout for the E5394A Single-Ended Soft Touch Probe

The following graphic and table show the E5394A single-ended soft touch probe pad numbers and logic analyzer pod inputs.

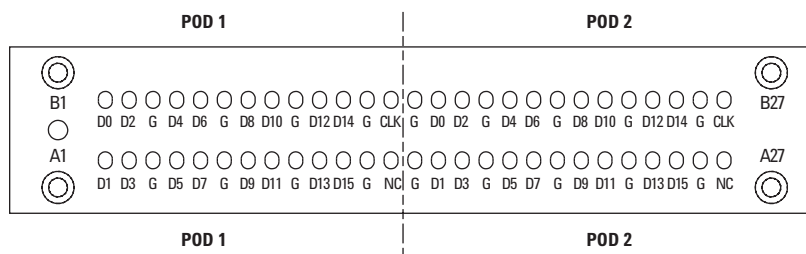


Figure 5.12. Pinout

E5394A Single-Ended Probe Signal Name	Pad #	Logic Analyzer Channel	Pod
D1	A1	→ 1	Whichever pod is connected to "Odd" on the E5394A probe
D3	A2	→ 3	
Ground	A3		
D5	A4	→ 5	
D7	A5	→ 7	
Ground	A6		
D9	A7	→ 9	
D11	A8	→ 11	
Ground	A9		
D13	A10	→ 13	
D15	A11	→ 15	
Ground	A12		
NC	A13	→ NC	
Ground	A14		
D1	A15	→ 1	
D3	A16	→ 3	
Ground	A17		
D5	A18	→ 5	
D7	A19	→ 7	
Ground	A20		
D9	A21	→ 9	
D11	A22	→ 11	
Ground	A23		
D13	A24	→ 13	
D15	A25	→ 15	
Ground	A26		
NC	A27	→ NC	

E5394A Single-Ended Probe Signal Name	Pad #	Logic Analyzer Channel	Pod
D0	B1	→ 0	Whichever pod is connected to "Odd" on the E5394A probe
D2	B2	→ 2	
Ground	B3		
D4	B4	→ 4	
D6	B5	→ 6	
Ground	B6		
D8	B7	→ 8	
D10	B8	→ 10	
Ground	B9		
D12	B10	→ 12	
D14	B11	→ 14	
Ground	B12		
Clock	B13	→ Clock	
Ground	B14		
D0	B15	→ 0	
D2	B16	→ 2	
Ground	B17		
D4	B18	→ 4	
D6	B19	→ 6	
Ground	B20		
D8	B21	→ 8	
D10	B22	→ 10	
Ground	B23		
D12	B24	→ 12	
D14	B25	→ 14	
Ground	B26		
Clock	B27	→ Clock	

Designing and Probing with Target Connections For All Agilent Logic Analyzers with 40-pin Pod Connectors

Pinout for the E5396A 17-channel Single-Ended Soft Touch Probe

The following graphic and table show the E5396A single-ended soft touch probe pad numbers and logic analyzer pod inputs.

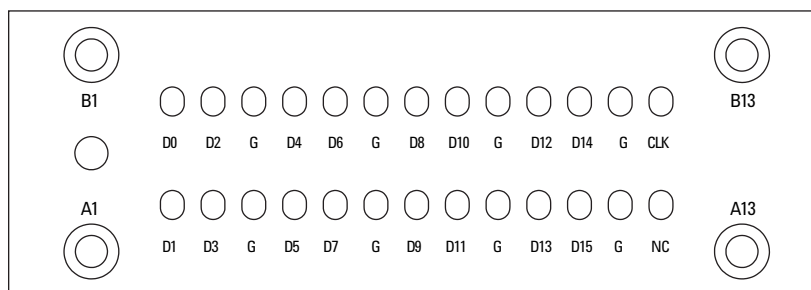


Figure 5.13. Pinout

E5396A 17-channel Single-Ended Probe

Signal Name	Pad #	Logic Analyzer Channel	Pod
D1	A1	→ 1	Whichever pod is plugged into the E5396A probe
D3	A2	→ 3	
Ground	A3		
D5	A4	→ 5	
D7	A5	→ 7	
Ground	A6		
D9	A7	→ 9	
D11	A8	→ 11	
Ground	A9		
D13	A10	→ 13	
D15	A11	→ 15	
Ground	A12		
NC	A13	→ n/a	

E5396A 17-channel Single-Ended Probe

Signal Name	Pad #	Logic Analyzer Channel	Pod
D0	B1	→ 0	Whichever pod is plugged into the E5396A probe
D2	B2	→ 2	
Ground	B3		
D4	B4	→ 4	
D6	B5	→ 6	
Ground	B6		
D8	B7	→ 8	
D10	B8	→ 10	
Ground	B9		
D12	B10	→ 12	
D14	B11	→ 14	
Ground	B12		
Clock	B13	→ Clock	

Designing and Probing with Target Connections

For All Agilent Logic Analyzers with 40-pin Pod Connectors

Equivalent Probe Loads

The following probe load models are based on in-circuit measurements made with an Agilent 8753E 6 GHz network analyzer and an Agilent 54750A TDR/TDT using a 50 Ω test fixture. The following schematic accurately models the probe load out to 6 GHz.

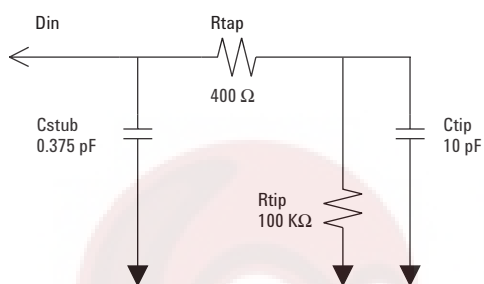


Figure 5.14. Simple (does not include capacitive coupling between channels or inductance of the spring pins)

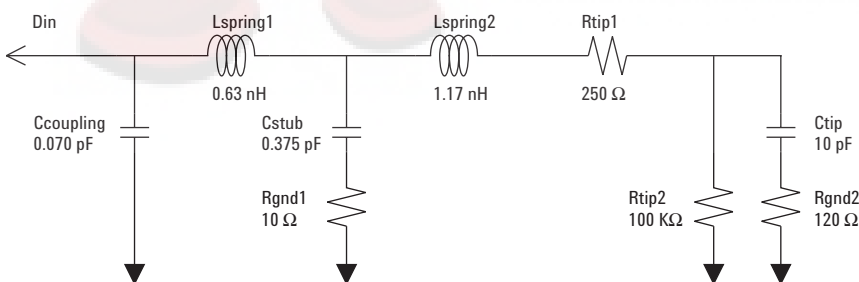


Figure 5.15. Complex (includes capacitive coupling between channels and inductance of spring pins)

Designing and Probing with Target Connections

For All Agilent Logic Analyzers with 40-pin Pod Connectors

High Density, High Performance

Agilent Technologies has developed high-density probing solutions based on the 100-pin Samtec and AMP Mictor 38-pin connectors. The Agilent probes and adapter cables, E5346A, E5339A, E5351A, and E5385A provide a connection strategy to route your important signals to the Agilent logic analyzer. Simply design the connectors onto the board for the critical signals such

as address, data, and status bits. The connectors consume a minimal amount of board space. Each connector provides 32 channels of logic analysis per connector and two clocks (unused clocks can be used as data). Connectors for use with the E5385A, E5346A, E5339A and E5351A can be purchased directly from AMP, Samtec, or Agilent Technologies. See the “Related Information” at the end of this document.

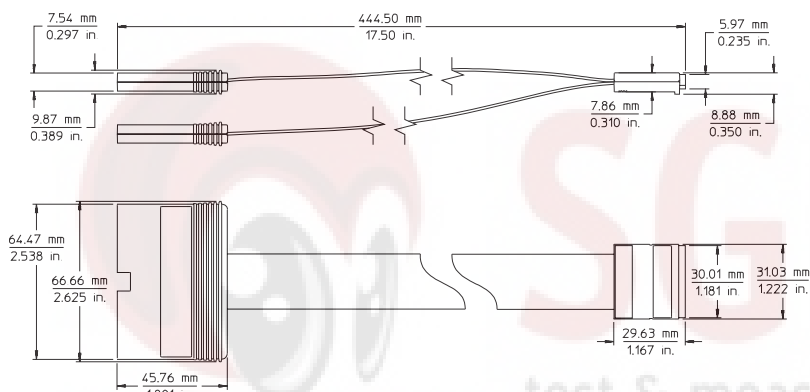


Figure 5.16. E5385A 100-pin probe mechanical dimensions

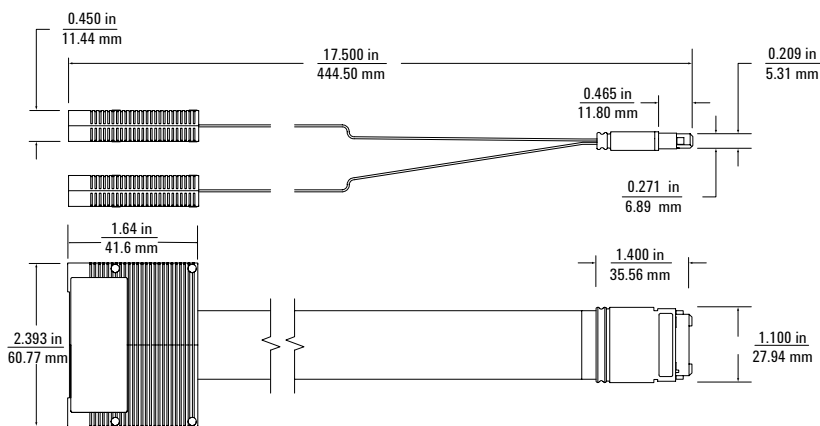


Figure 5.17. E5346A, E5351A, E5339A mechanical dimensions

Designing and Probing with Target Connections

For All Agilent Logic Analyzers with 40-pin Pod Connectors

Agilent Technologies E5346A, E5339A, and E5385A Probes

The E5346A, E5339A, and E5385A probes include the required isolation networks for the logic analyzer right at the probe tip, close to the target. The E5346A and E5385A are designed to acquire signals with peak-to-peak amplitude as low as 500 mV. The E5339A is designed to acquire signals as small as 250 mV peak-to-peak. Figure 5.18 shows the equivalent load for the E5339A, and Figure 5.19 shows the equivalent load for the E5346A. Figure 5.20 shows the equivalent load for the E5385A.

To use the E5346A, E5339A, or E5385A at high clock speeds, the following design guidelines should be observed:

- Calculate the electrical length of the probe hookup stub.
- For PC board material with $E_r=4.9$, use a propagation delay of 160 ps/inch.
- Check that the propagation delay of the probe hookup stub is less than 20% of the bus signal risetime (T_r). If it is, the E5346A, E5339A, or E5385A can be used for connection.

For example, if $E_r=4.9$, a 2.5 inch probe hookup stub generates a propagation delay of 400 ps. If T_r is > 2 ns, the E5346A, E5339A, or E5385A is a viable probing choice.

The E5346A and E5339A use the AMP Mictor 38-pin connector. The E5385A uses a 100-pin connector manufactured by Samtec. Agilent recommends the E5394A or E5385A for new applications, due to the reduced input capacitive loading and improved isolation between adjacent channels.

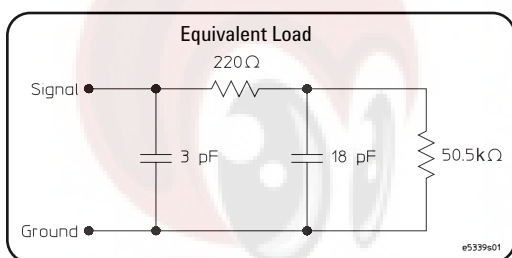


Figure 5.18. E5339A input equivalent load

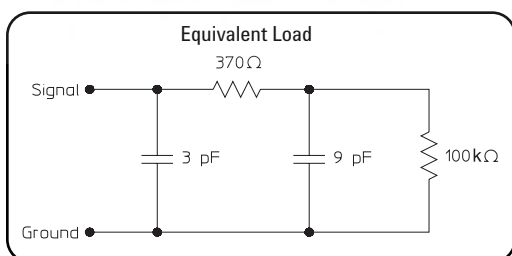


Figure 5.19. E5346A input equivalent load

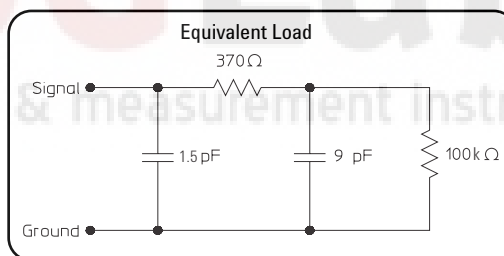


Figure 5.20. E5385A input equivalent load

For additional information on designing connectors into a target system, refer to the following documents:

Agilent Technologies E5346A/E5351A Probe/Adapter Cable	Installation Note E5346-92014	http://literature.agilent.com/litweb/pdf/E5346-92014.pdf
Agilent Technologies E5339A Low Voltage Probe	Installation Note E5339-92002	http://literature.agilent.com/litweb/pdf/E5339-92002.pdf
Agilent Technologies E5385A Probe	Installation Note E5385-92001	http://literature.agilent.com/litweb/pdf/E5385-92001.pdf

Designing and Probing with Target Connections

For All Agilent Logic Analyzers with 40-pin Pod Connectors

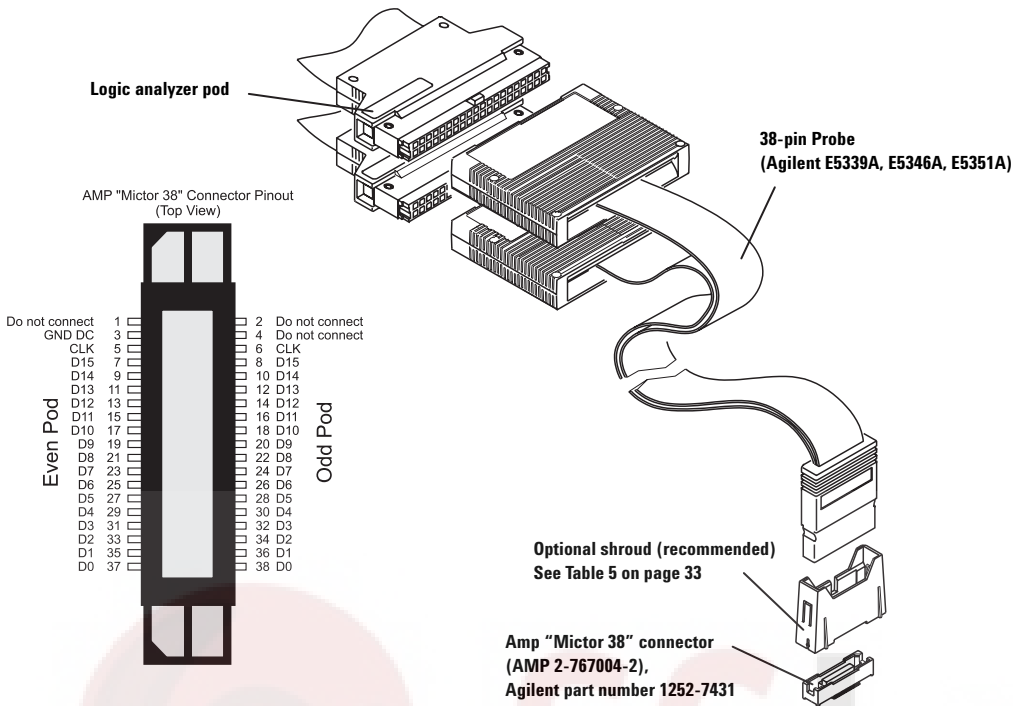


Figure 5.21. Agilent E5339A, E5346A, and E5351A connection and pinout

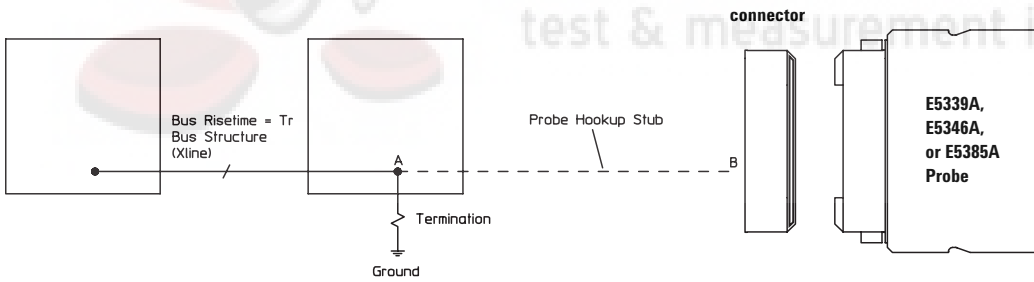


Figure 5.22. Agilent E5339A, E5346A, and E5385A design rules

Designing and Probing with Target Connections

For All Agilent Logic Analyzers with 40-pin Pod Connectors

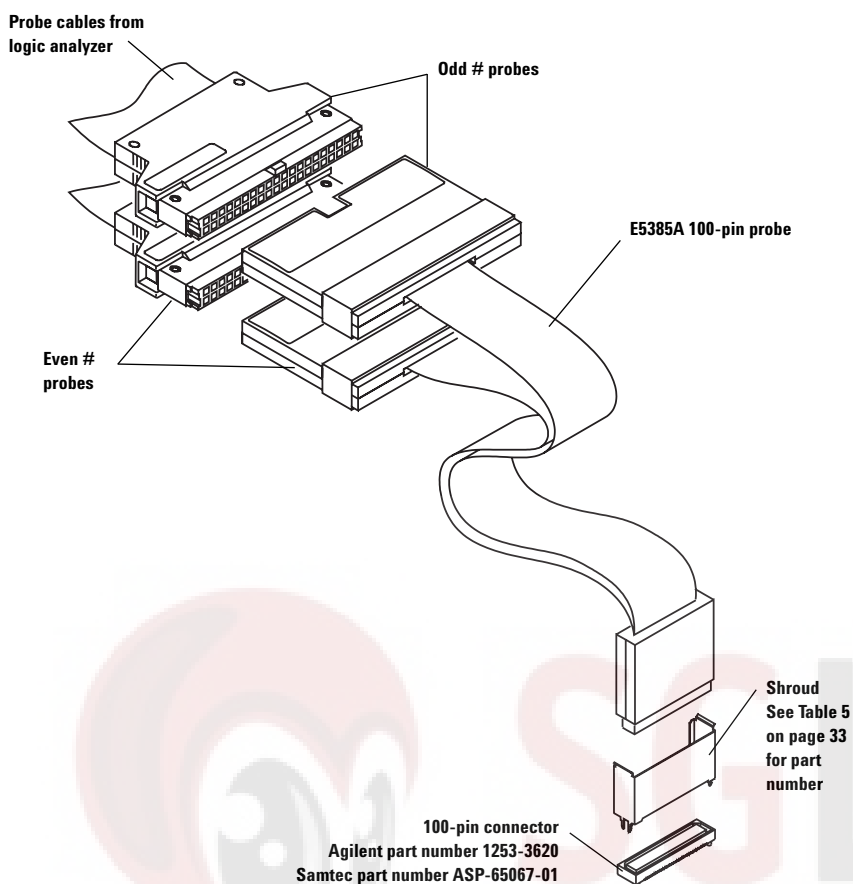


Figure 5.23. Agilent E5385A connection and pinout

E5385A 100-Pin Probe Pin Assignments

Signal	Pin Number	Signal	
Ground	1	2	Ground
Do Not Connect	3	4	Do Not Connect
Ground	5	6	Ground
Odd D0	7	8	Even D0
Ground	9	10	Ground
Odd D1	11	12	Even D1
Ground	13	14	Ground
Odd D2	15	16	Even D2
Ground	17	18	Ground
Odd D3	19	20	Even D3
Ground	21	22	Ground
Odd D4	23	24	Even D4
Ground	25	26	Ground
Odd D5	27	28	Even D5
Ground	29	30	Ground
Odd D6	31	32	Even D6
Ground	33	34	Ground
Odd D7	35	36	Even D7
Ground	37	38	Ground
Odd D8	39	40	Even D8
Ground	41	42	Ground
Odd D9	43	44	Even D9
Ground	45	46	Ground
Odd D10	47	48	Even D10
Ground	49	50	Ground
Odd D11	51	52	Even D11
Ground	53	54	Ground
Odd D12	55	56	Even D12
Ground	57	58	Ground
Odd D13	59	60	Even D13
Ground	61	62	Ground
Odd D14	63	64	Even D14
Ground	65	66	Ground
Odd D15	67	68	Even D15
Ground	69	70	Ground
NC	71	72	NC
Ground	73	74	Ground
NC	75	76	NC
Ground	77	78	Ground
Odd D16P/ Odd CLK	79	80	Even D16P/ Even CLK
Ground	81	82	Ground
NC	83	84	NC
Ground	85	86	Ground
NC	87	88	NC
Ground	89	90	Ground
NC	91	92	NC
Ground	93	94	Ground
Ground	95	96	Ground
+5V	97	98	+5V
+5V	99	100	+5V

Designing and Probing with Target Connections

For All Agilent Logic Analyzers with 40-pin Pod Connectors

Agilent Technologies E5351A 38-Pin Adapter Cable

If the calculated electrical length of the required routing stub prohibits the use of the Agilent E5339A, E5346A, or E5385A, the Agilent E5351A can be used with the required isolation networks installed on the target.

The E5351A does not have its own internal isolation networks. When using the E5351A, place the SIP isolation networks, surface mount isolation network 5062-7396, or equivalent discrete components very near the target component for measurement.

Ensure that the stub length between the target component and the isolation network is short. The stub propagation delay should be less than 20% of the bus signal rise time, as mentioned before. The transmission line from the on-board isolation network to the Mictor connector should be designed for an impedance in the range of 80 to 100 ohms (closer to 100 ohms is better). This length should not exceed 3 to 4 inches, and all signal line lengths should be equal. Signal line length variation should not cause propagation delay variation to exceed 20 ps between signal lines.

Notes on Using Discrete Components

Discrete components can be used in the design of the RC network. Agilent Technologies recommends the circuit shown in Figure 5.25. To achieve the equivalent load shown in the figure, trace lengths should be minimized by locating the RC network very near the measured node. Actual load will be the stub length load added to the equivalent load in the figure.

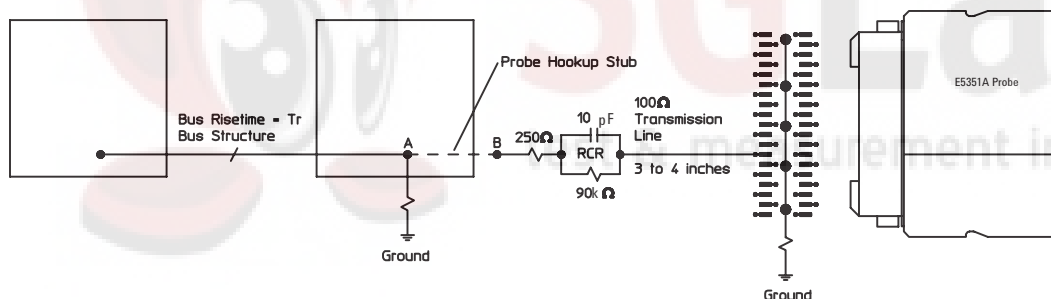


Figure 5.24. Agilent Technologies E5351A design rules

Designing and Probing with Target Connections

For All Agilent Logic Analyzers with 40-pin Pod Connectors

Options for On-Board Terminations for the E5351A

There are two options for isolating the E5351A on the target PC board:

- Use the surface mount isolation network, Agilent part number 5062-7396. Refer to Figure 5.26 for schematic and pinout.
- Use discrete components. Refer to Figure 5.25 for recommended components and equivalent load.

If you are operating at state speeds above 200 MHz, you should use discrete components for best results. Due to the added electrical length of the E5351A probe cable, the divider compensating capacitors in the SIP, and surface-mount isolation networks are not optimum for the E5351A, but they are usable up to 200 MHz clock rates.

Notes on Using the 5062-7396 SMT Part

Agilent currently recommends a two-step process in soldering the SMT part to the board. The first pass places solder paste on those pads with vias. Application of heat allows the via to fill with solder. (If only one solder step is used, the solder wicks away from the part into the via and a solid connection will not be made with the part.) The next pass places solder paste on all of the pads.

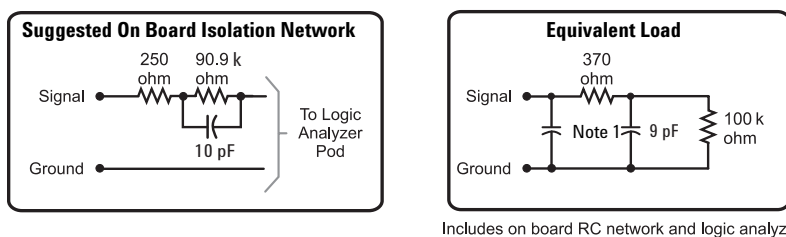


Figure 5.25. Suggested on-board isolation network and equivalent load when using discrete components to terminate the E5351A

Note 1: The effective input capacitance for on-board isolation networks is purely a function of geometry - 0.3 pF is about as low as can be achieved.
 Note 2: The equivalent load is the same when using the surface-mount isolation network, 5062-7396.

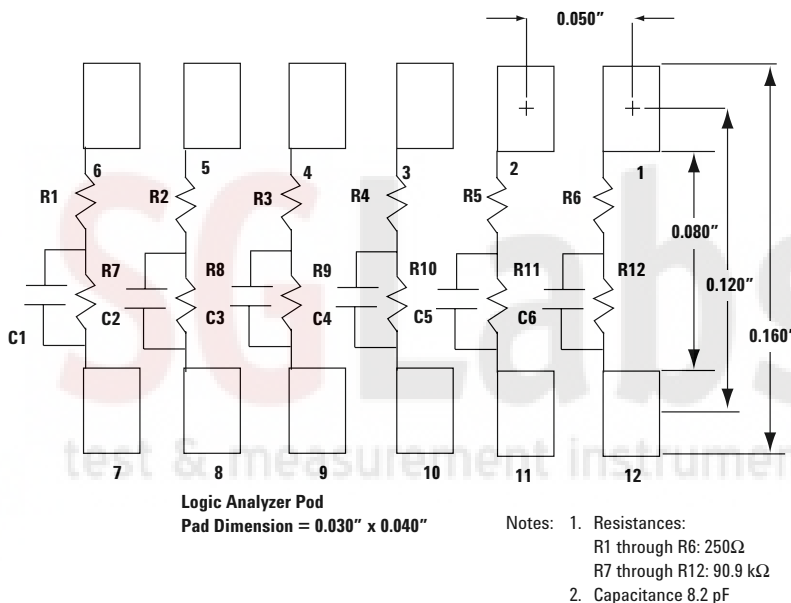


Figure 5.26. Recommended PC board pattern for 5062-7396 surface mount isolation network

As shown in Figure 5.26, the 5062-7396 SMT isolation network supports six logic analysis channels. The size of the part allows you to repeat the pattern in Figure 5.26 to accommodate multiple parts stacked end-to-end for the number of channels needed in your application. Three of these SMTs are required for each probe

cable. The process for using the ceramic hybrid isolation network is similar to the process for an LCC package. Due to the small part size, thermal expansion mismatch during solder reflow should not be a problem. Capacitance also remains stable with temperature changes.

Designing and Probing with Target Connections

For All Agilent Logic Analyzers with 40-pin Pod Connectors

Support Shrouds

A support shroud is recommended to provide additional strain relief between the probe and the connector, as shown in Figures 5.21 and 5.23. Two plated through-holes are required on the target board. The shroud is mounted directly to the target board using the through-holes. This places the shroud around the connector, providing solid mechanical strain relief. Connector kits are available; Table 5 shows the Agilent part numbers for shrouds and connector kits for various PC board thicknesses.

For probe model numbers	Description	Agilent part number
E5339A, E5346A, E5351A	Kit of five support shrouds and five 38-pin Mictor connectors for PC board thickness up to 1.57 mm (0.062")	E5346-68701
	Kit of five support shrouds and five 38-pin Mictor connectors for PC board thickness up to 3.175 mm (0.125")	E5346-68700
	One 38-pin Mictor connector (also available from AMP as part number 2-767004-2)	1252-7431
	One support shroud for PC board thickness up to 1.57 mm (0.062")	E5346-44701
	One support shroud for PC board thickness up to 3.175 mm (0.125")	E5346-44704
E5385A	One support shroud for PC board thickness up to 4.318 mm (0.700")	E5346-44703
	Kit of five support shrouds and five 100-pin Samtec connectors for PC board thickness up to 1.57 mm (0.062")	16760-68702
	Kit of five support shrouds and five 100-pin Samtec connectors for PC board thickness up to 3.05 mm (0.120")	16760-68703
	One 100-pin Samtec connector (also available from Samtec as part number ASP-65067-01)	1253-3620
	One support shroud for PC board thickness up to 1.57 mm (0.062")	16760-02302
	One support shroud for PC board thickness up to 3.05 mm (0.120")	16760-02303

Table 5. Mating connectors, shrouds, and kits for Agilent E5339A, E5346A, E5351A, and E5385A probes

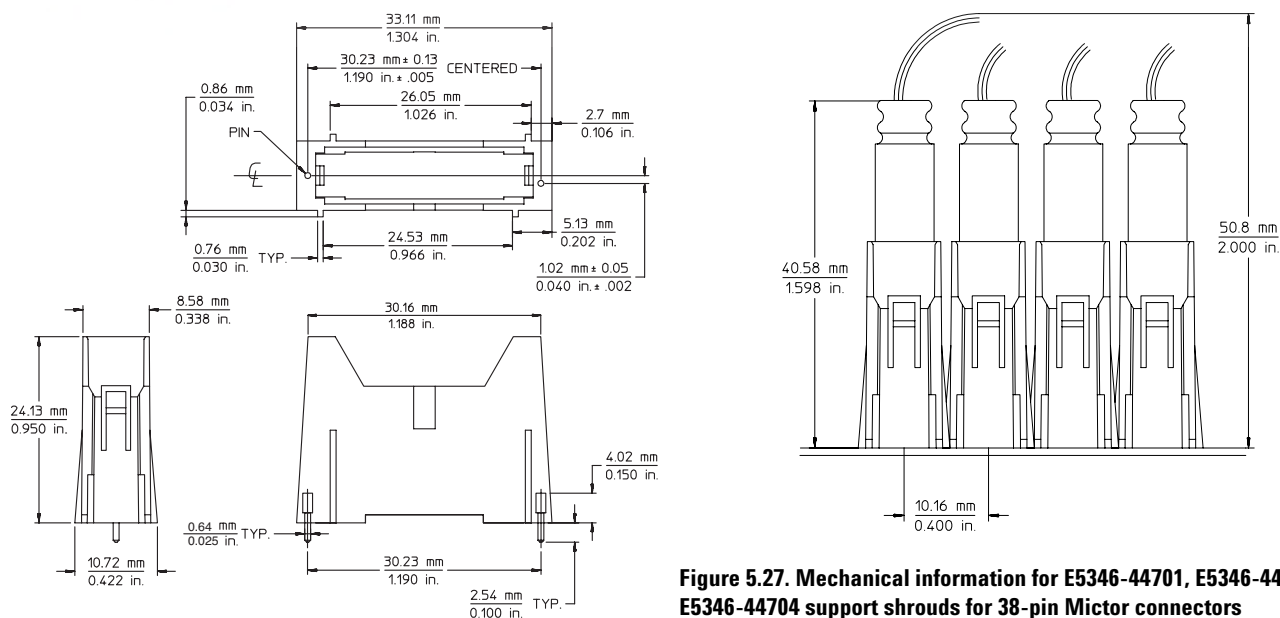


Figure 5.27. Mechanical information for E5346-44701, E5346-44703, E5346-44704 support shrouds for 38-pin Mictor connectors

Designing and Probing with Target Connections

Probing Individual Pins of High-Density Connectors

38-pin Mictor Adapter

Signals routed out to AMP Mictor connectors can also be accessed by other test equipment, such as an oscilloscope.

The E5346-60002 plugs directly into the Mictor connector and brings all 32 signals out to standard connector pins through flex circuits, as shown in Figure 6.1.

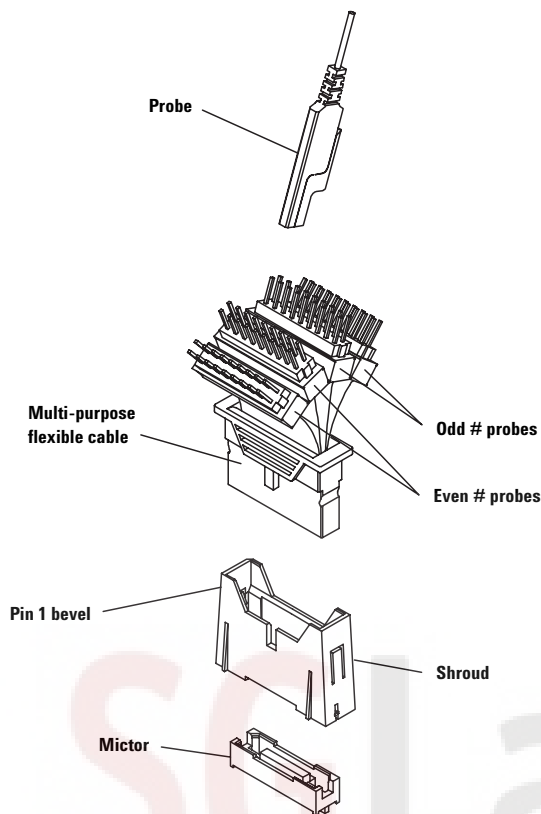


Figure 6.1. E5346-60002 Mictor break-out adapter

Designing and Probing with Target Connections

Right-Angle Mictor Adapter

For systems with space constraints above the 38-pin connector, Agilent Technologies offers a right-angle adapter, as shown in Figure 7.1. With the E5346-63201 right-angle adapter inserted in the 38-pin connector, the adapter cable is connected parallel to the target board surface. When using the right-angle adapters, the 38-pin connectors must be placed end-to-end on the target board, as shown in Figure 7.2. Support shrouds cannot be used with the right-angle adapter.

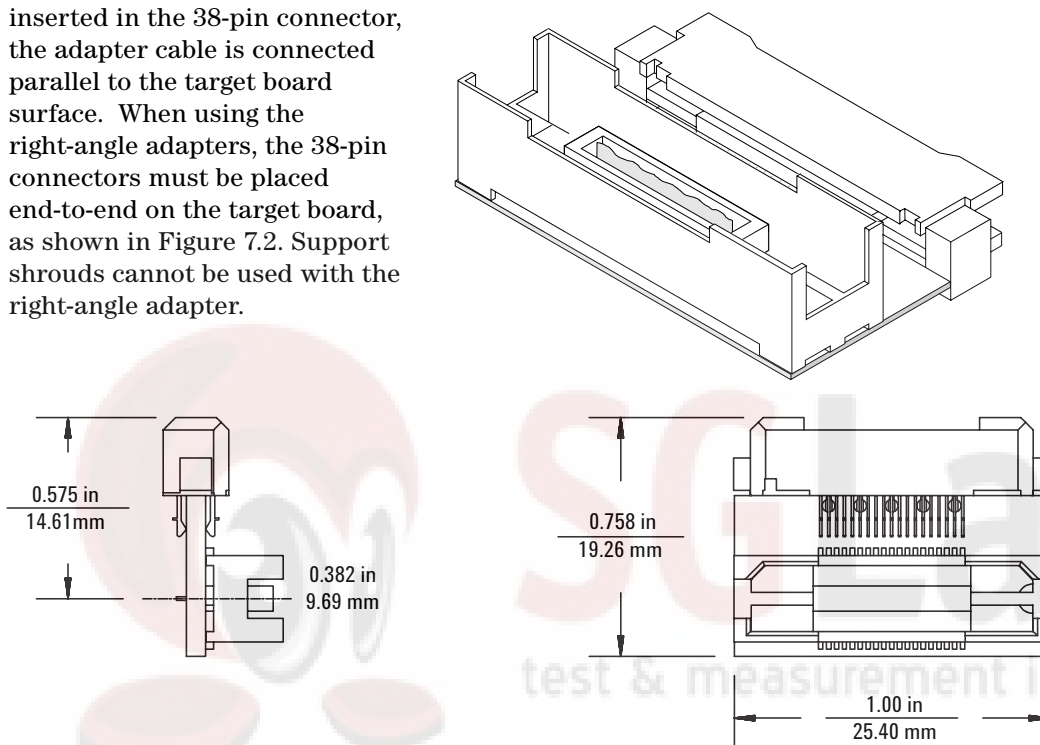


Figure 7.1. E5346-63201 right-angle 38-pin adapter

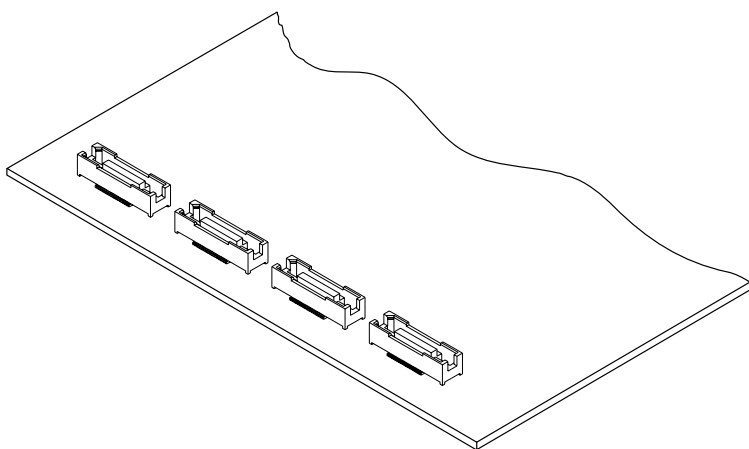


Figure 7.2. 38-pin connectors placed for use of right-angle adapter

Note: the right-angle adapter adds significant capacitance and inductance in series with the probe. It is not recommended for state speeds above 100 MHz or for signals with rise times < 4 - 5 ns.

Designing and Probing with Target Connections

For All Agilent Logic Analyzers with 40-pin Pod Connectors

Low Density, Moderate Performance

Solutions shown in the “High-Density, High-Performance” (page 27) section of this document can be used in place of the solutions described here. Agilent recommends standard 0.1 inch center connectors for normal density applications if the loading/speed is not a significant issue. Many of these items are available from 3M or Agilent (see Table 6). See the “Related Information” section at the end of this document for 3M address information.

Direct Connection through Isolation Adapter

Isolation adapters (Agilent part number 01650-63203) that connect to the end of the probe cable are designed to perform two functions. The first is to reduce the number of pins required for the header on the target board from 40 pins to 20 pins. This process reduces the board area dedicated to the probing connection. The second function is to provide the proper RC networks in a very convenient package. Figure 7.3 illustrates how the isolation adapter physically connects to the target system and the equivalent load of the isolation adapter connected to an Agilent Technologies logic analyzer. Figures 7.4 and 7.5 show the pinout diagrams for the probe cable and the isolation adapter, respectively. There are two 20-pin connectors, along with their Agilent Technologies and 3M part numbers, listed in Table 6.

Note: The Agilent 01650-63203 saves space by using a common ground (see Figure 7.5). This will impact signal fidelity, especially faster transition times (< 4 - 5 ns).

Agilent Part Number	3M Part Number	Connector Description
1251-8106	2520-6002	20-Pin, low-profile (straight)
1251-8473	2520-5002	20-Pin, low-profile (right-angle)

Table 6. Twenty-pin connectors for fixed configuration probing. (Requires isolation adapter)

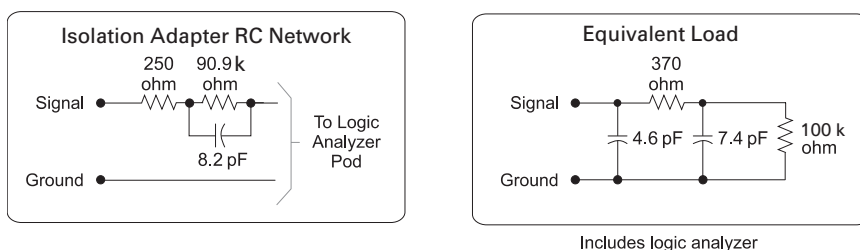
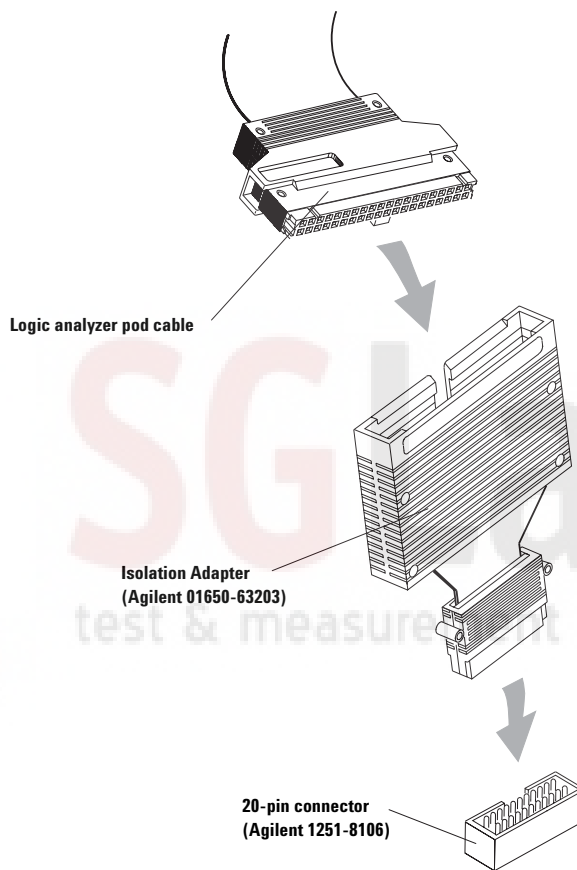


Figure 7.3. Isolation adapter (01650-63203) and equivalent load

Designing and Probing with Target Connections For All Agilent Logic Analyzers with 40-pin Pod Connectors

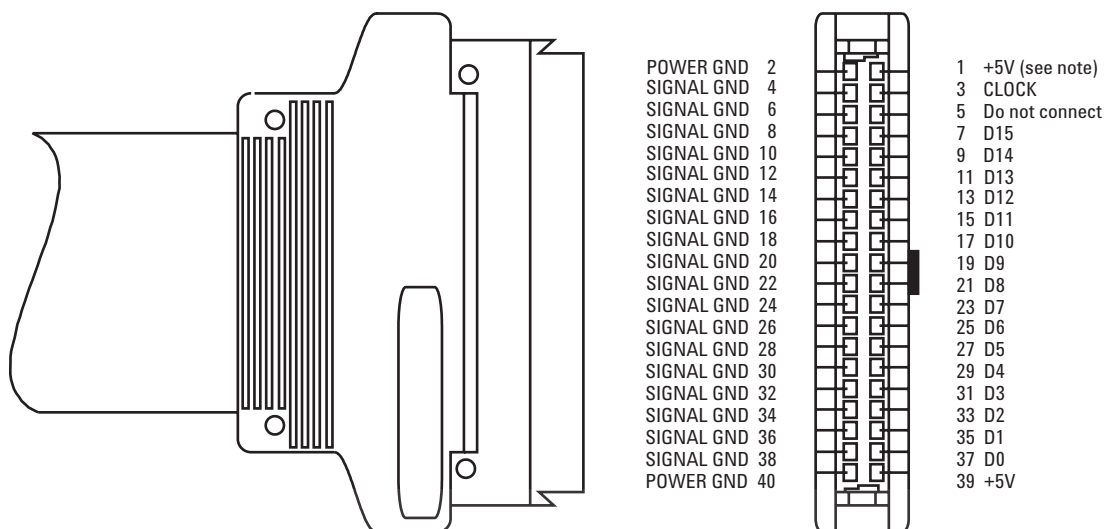


Figure 7.4. Pinout for probe cable

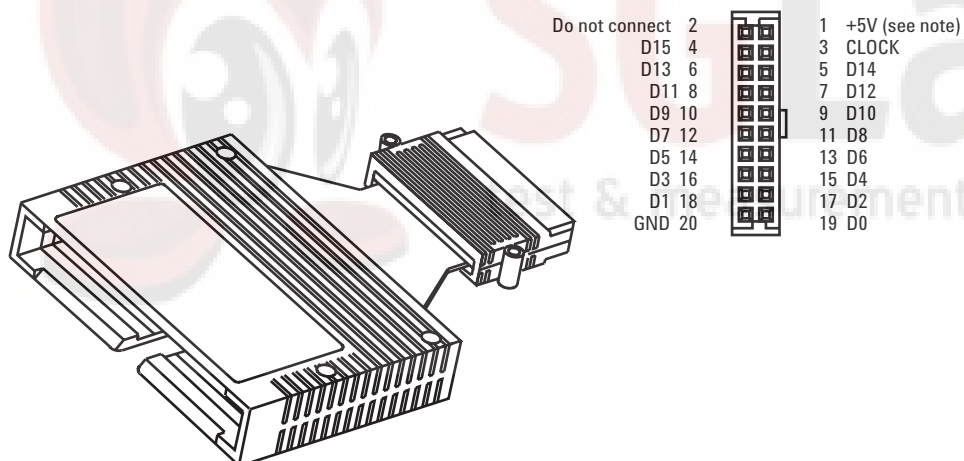


Figure 7.5. Pinout for 100 kΩ isolation adapter (Agilent part number 01650-63203)

Note: +5V is supplied from the logic analyzer to provide power for analysis probes and demo boards. **DO NOT connect these pins to a +5V supply in the target system!**

Designing and Probing with Target Connections

For All Agilent Logic Analyzers with 40-pin Pod Connectors

Direct Connection through 40-Pin Connectors

The probe cable also can be plugged directly into the various 40-pin connectors shown in Table 7, but proper isolation networks must be installed directly onto the target system board (see Figure 7.6 for the 40-pin connector pinout).

Agilent Technologies offers a 12-pin SMT (Agilent part number 5062-7396), which provides six isolation networks, as shown in Figure 7.7. Three of these SMTs are required for each probe cable.

Discrete components can also be used for the proper isolation network. See Figure 7.9 for an equivalent load diagram for the isolation networks.

Note that the effective input capacitive lead of an isolation network using discrete components is a function of the layout geometry and the parasitic capacitance of the input series damping resistor.

Agilent Part Number	3M Part Number	Connector Description
1251-8828C	2540-6002	40-Pin, low-profile (straight)
1251-8158	2540-5002	40-Pin, low-profile (right-angle)
1251-8831	3432-6302	40-Pin, with long latches (straight)
1251-8931	3432-5302	40-Pin, with long latches (right-angle)

Table 7. Forty-pin connectors for fixed configuration probing. (Requires isolation network installed on target board)

Agilent Part Number	Package Type
5062-7396	SMT, 12-pin, provides 6 isolation networks (3 SMTs required for each probe cable)

Table 8. Available isolation networks

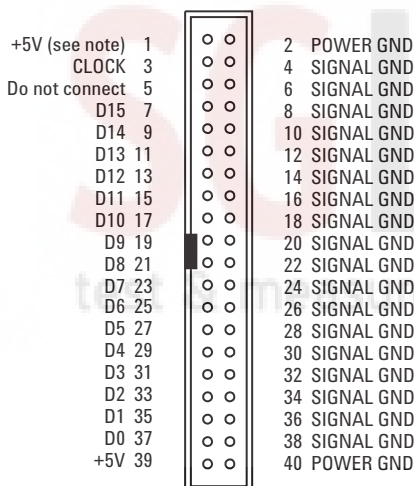


Figure 7.6. Forty-pin connector pinout

Note: +5V is supplied from the logic analyzer to provide power for analysis probes and demo boards. **DO NOT connect these pins to a +5V supply in the target system!**

Designing and Probing with Target Connections

For All Agilent Logic Analyzers with 40-pin Pod Connectors

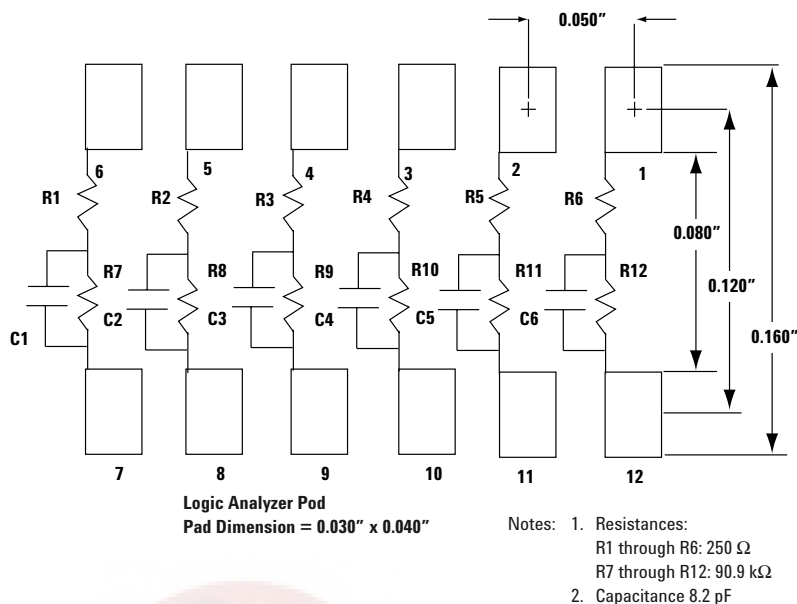


Figure 7.7. Recommended PC board pattern for 5062-7396 surface mount isolation network

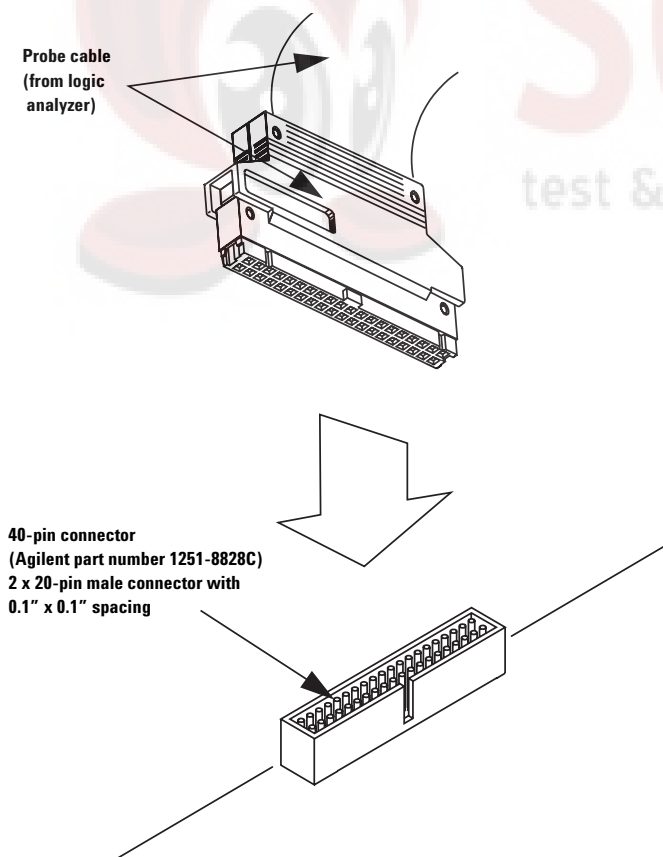


Figure 7.8. Connecting probe cable to 40-pin connector with isolation networks

Designing and Probing with Target Connections

For All Agilent Logic Analyzers with 40-pin Pod Connectors

Notes on Using Discrete Components

Discrete components can be used to design the isolation network. Agilent Technologies recommends the circuit shown in Figure 7.9. To achieve the equivalent load shown in the figure, trace lengths should be minimized by locating the RC network very near the measured node. Actual load will be the stub length load added to the equivalent load in the figure. Trace length from the suggested on-board RC network to the target connector must be 3 to 4 inches or less. This transmission line should be designed for an impedance in the range of 80 to 100 ohms (closer to 100 ohms is better).

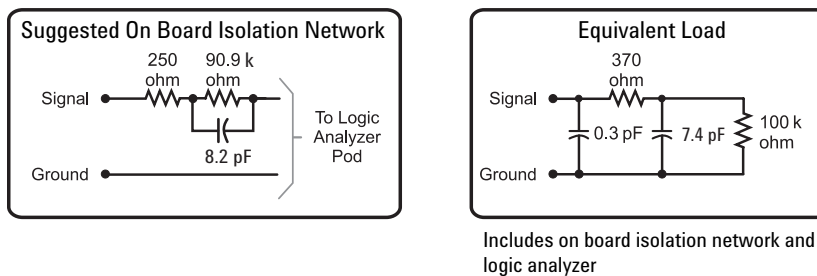


Figure 7.9. Equivalent load for on-target discrete components.
Also applies to SMT (5062-7396) RC networks.



SG Labs

test & measurement instruments

Designing and Probing with Target Connections

Agilent Logic Analyzers with 90-pin Pod Connectors

Seven options are available for connecting Agilent logic analyzers with 90-pin pod connectors to a target system using mass connections.

Agilent Pro Series Soft Touch Connectorless Logic Analyzer Probes

Agilent Technologies has developed connectorless logic analyzer probes based on soft touch probing technology. Connectorless logic analyzer probing removes the connector that is traditionally attached to the target board and replaces it with an array of probe pads. This reduces the probe load on the target by eliminating the loading associated with the physical body of the connector. Additionally, this streamlines the

design flow by eliminating the need to assign a logic analyzer connector to the bill of material of your board, procuring those connectors and then having them loaded onto your board.

Agilent's soft touch connectorless probes use micro spring-pin technology to provide reliable contact which is not dependent on the planarity of the PC board or the plating processes used to fabricate the board. No special cleaning processes are required when using Agilent's soft touch probes.

The new Agilent Technologies Pro Series soft touch connectorless probes offer a 30% smaller footprint than the original soft touch

probes and are the basis for the industry standard connectorless probing footprint.

The probes use a retention module that ensures soft touch pin-to-PC board pad alignment and holds the probe in place while in use. The Pro Series soft touch uses a "top-side" mountable retention module. The retention module is mounted on the same side of the board as the probing footprint so there is no need to access the back-side of the board. Because there is no requirement for the retention module pins to extend beyond the back-side of the board, the retention module is compatible with virtually any board thickness.

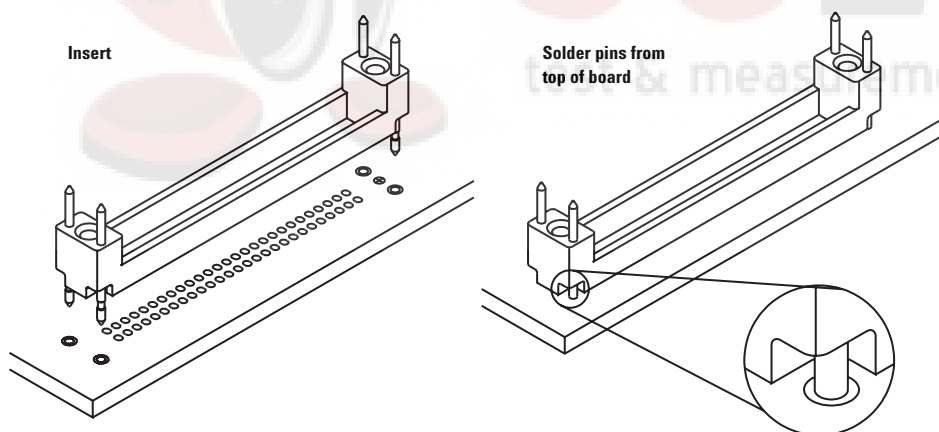


Figure 8.1. "Top-side" mountable retention module.

Designing and Probing with Target Connections

Agilent Logic Analyzers with 90-pin Pod Connectors

E5405A Differential Pro Series Soft Touch Connectorless Probe

The E5405A is a 17-channel differential Pro Series soft touch connectorless probe compatible with all Agilent logic analyzers that have a 90-pin pod connector. It is capable of acquiring data at the maximum rates of the logic analyzer it is connected to.

Features

- No connector on the target board
- Top-side retention module
- Industry-standard connectorless footprint
- 17 channels, differential or single-ended clock and data
- Extremely low, <0.7 pF, equivalent load capacitance
- Capable of data rates >2.5 Gb/s (maximum rate dependent on analyzer used)
- 200 mV $V_{\max}-V_{\min}$ minimum signal amplitude
- Robust and reliable soft touch technology

Unused clock inputs can be used as data inputs.

The E5405A uses the same retention module as the E5404A and E5406A Pro Series soft touch connectorless probe.

A kit of five retention modules is shipped with each Pro Series soft touch probe. Additional kits can be ordered using Agilent part number E5403A.

E5406A Pro Series Soft Touch Connectorless Probe

The E5406A is a 34-channel single-ended Pro Series soft touch connectorless probe compatible with all Agilent logic analyzers that have a 90-pin pod connector. It is capable of acquiring data at the maximum rates of the logic analyzer it is connected to.

Features

- No connector on the target board
- Top-side mount retention module
- Industry-standard connectorless footprint
- 34 channels, single-ended or differential clock and single-ended data
- Extremely low, <0.7 pF, equivalent load capacitance
- Capable of data rates >2.5 Gb/s (maximum rate dependent on analyzer used)
- 250 mV p-p minimum signal amplitude
- Robust and reliable soft touch technology

Unused clock inputs can be used as data inputs.

The E5406A (used with logic analyzers with a 90-pin cable connector) uses the same footprint, pinout, and retention module as the E5404A Pro Series soft touch connectorless probe (used with logic analyzers with a 40-pin cable connector).

A kit of five retention modules is shipped with each Pro Series soft touch probe. Additional kits can be ordered using Agilent part number E5403A.

E5387A Differential Soft Touch Connectorless Probe

The E5387A is a 17-channel differential soft touch connectorless probe compatible with all Agilent logic analyzers that have a 90-pin pod connector. It is capable of acquiring data at the maximum rates of the logic analyzer it is connected to. The probe has the following inputs:

- 16 differential or single-ended data inputs
- one differential or single-ended clock input
- < 0.7 pf input capacitance
- 200 mV $V_{\max}-V_{\min}$ minimum signal amplitude

Unused clock inputs can be used as data inputs.

The E5387A uses the same retention module as the E5390A and E5394A soft touch probes.

A kit of five retention modules is shipped with each soft touch probe. Additional kits can be ordered using Agilent part number E5387-68701.

Designing and Probing with Target Connections

Agilent Logic Analyzers with 90-pin Pod Connectors

E5390A Single-Ended Soft Touch Connectorless Probe

The E5390A is a 34-channel single-ended soft touch connectorless probe compatible with all Agilent logic analyzers that have a 90-pin pod connector. It is capable of acquiring data at the maximum rates of the logic analyzer it is connected to. The probe has the following inputs:

- 32 single-ended data inputs
- two differential or single-ended clock inputs
- < 0.7 pf input capacitance
- 250 mV p-p minimum signal amplitude

Unused clock inputs can be used as data inputs.

The E5390A (used with logic analyzers with a 90-pin pod connector) uses the same footprint, pinout and retention module as the E5394A single-ended soft touch connectorless probe (used with logic analyzers with a 40-pin pod connector).

A kit of five retention modules is shipped with each soft touch probe. Additional kits can be ordered using Agilent part number E5387-68701.

E5398A Half-Size Soft Touch Connectorless Probe

The E5398A is a small space saving probe compatible with all Agilent logic analyzers that have a 90-pin cable connector. It is a 17-channel, single-ended probe capable of capturing data at the maximum rates of the logic analyzer it is connected to. The probe has the following inputs:

- 16 single-ended data inputs
- one differential or single-ended clock input
- <0.7 pf equivalent load capacitance
- 250 mV p-p minimum signal amplitude

Unused clock inputs can be used as data inputs.

The E5398A (used with logic analyzers with a 90-pin cable connector) uses the same footprint, pinout, and retention module as the E5396A single-ended soft touch connectorless probe (used with logic analyzers with a 40-pin cable connector).

More information about soft touch connectorless probes is available on the web at www.agilent.com/find/softtouch

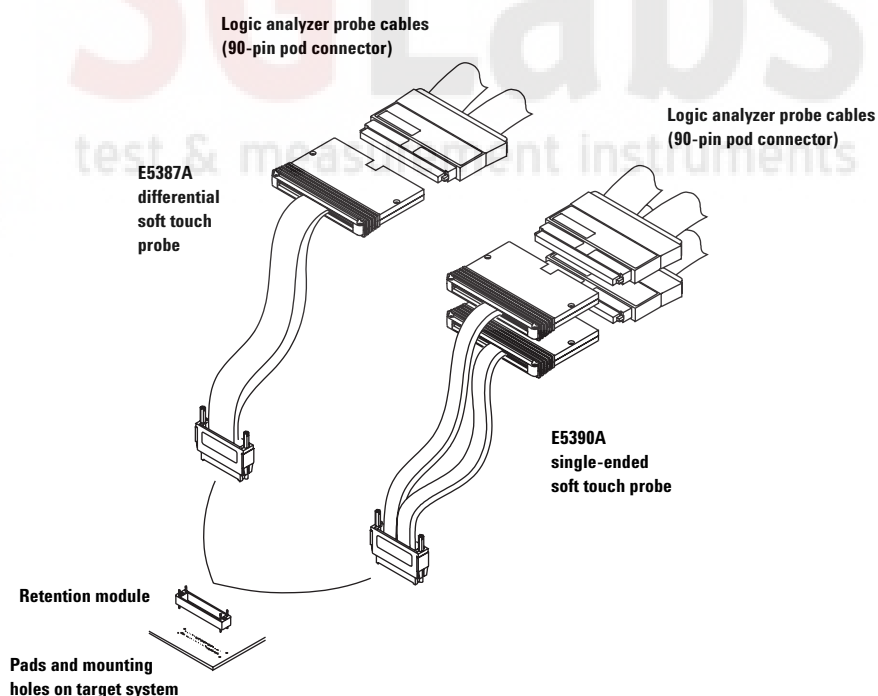


Figure 8.2. Soft touch probes

Designing and Probing with Target Connections

Agilent Logic Analyzers with 90-pin Pod Connectors

Probe Dimensions

The following figures show dimensions, footprint, and pinout information you will need to design your target system board for use with the Agilent soft touch probes.

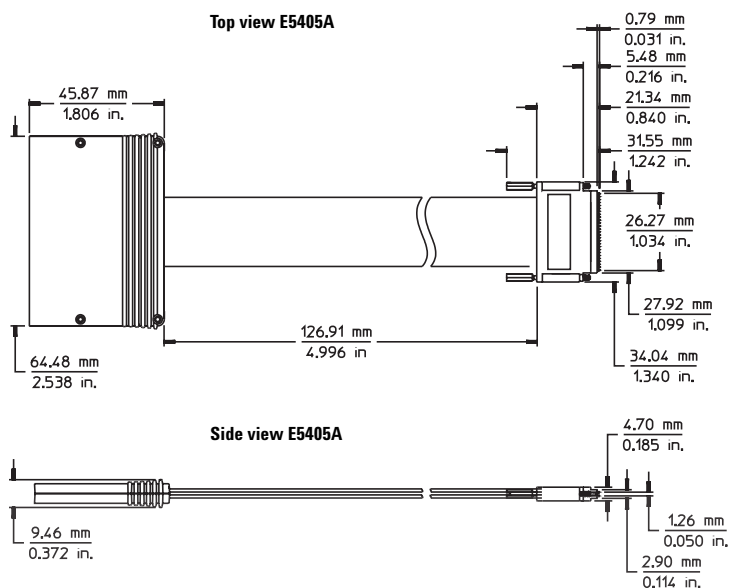


Figure 8.3. E5405A probe dimensions

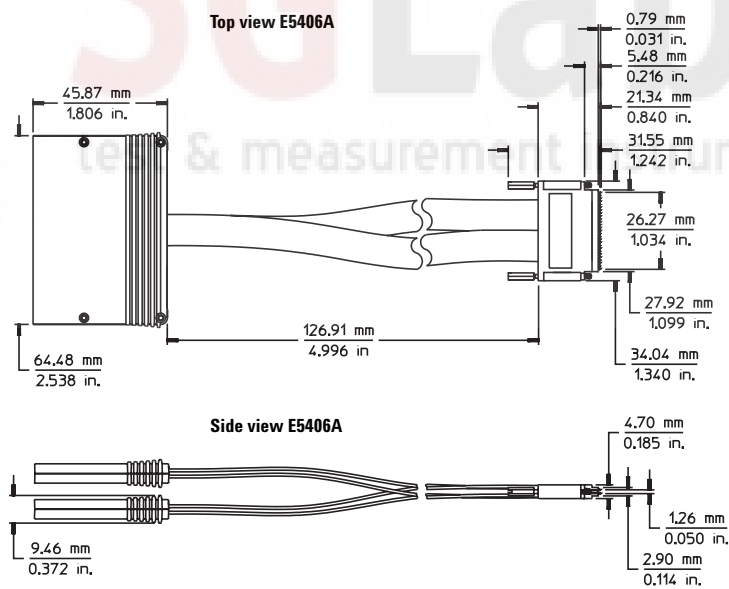


Figure 8.4. E5406A probe dimensions

Designing and Probing with Target Connections

Agilent Logic Analyzers with 90-pin Pod Connectors

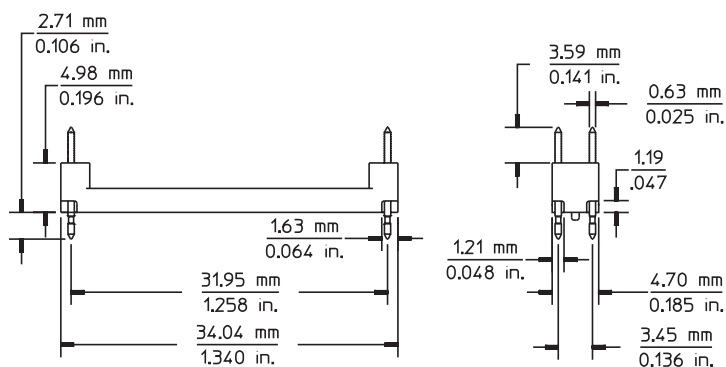


Figure 8.5. Pro Series soft touch retention module dimensions

Pro Series Soft Touch Retention Module Dimensions

The following dimensions show the soft touch probe attached to the retention module. The retention module is mounted on the PC board.

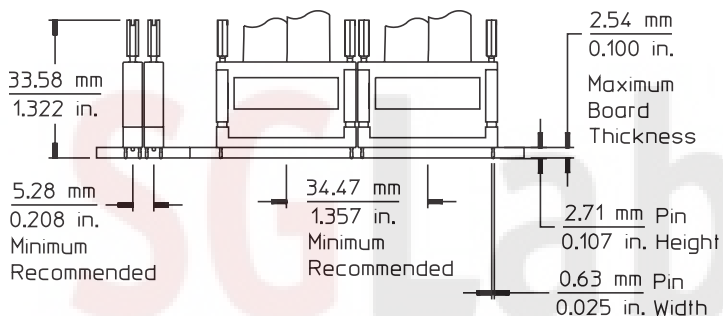
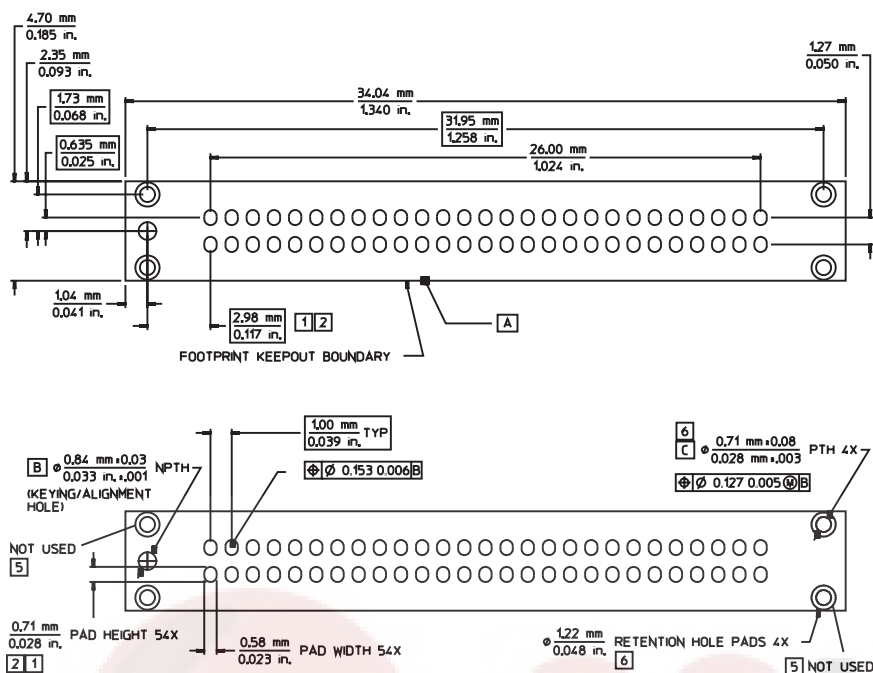


Figure 8.6. Pro Series soft touch side-by-side dimensions

Designing and Probing with Target Connections

Agilent Logic Analyzers with 90-pin Pod Connectors



Drawing notes:

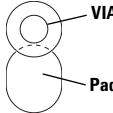
- 1 Maintain a solder mask web between pads when traces are routed between the pads on the same layer. The solder mask may not encroach onto the pads within the pad dimension shown.
- 2 VIAs not allowed on these pads. VIA edges may be tangent to pad edges as long as a solder mask web between VIAs and pads is maintained. 
- 3 Surface finishes on pads should be HASL immersion silver, or gold over nickel.
- 4 This footprint is compatible with retention module Agilent part number E5405-68702.
- 5 This through hole is not used with the Agilent retention module.
- 6 Plated through hole should not be tied to ground plane for thermal relief.

Figure 8.7. Pro Series soft touch footprint dimensions (see drawing notes).

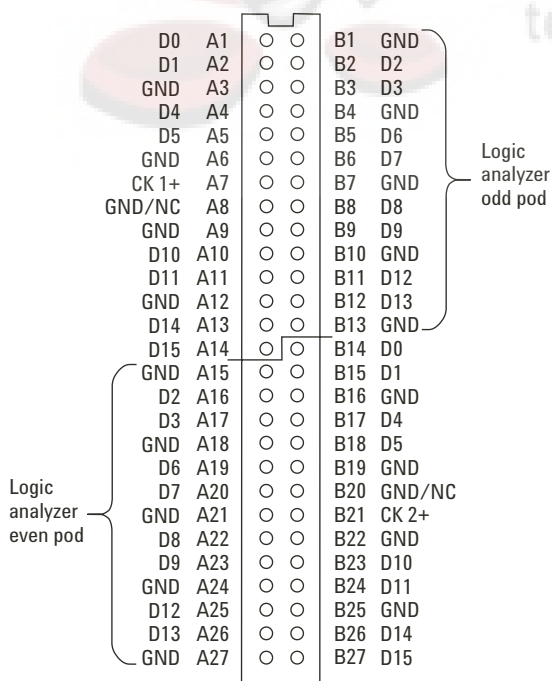


Figure 8.8. Pad numbers for E5404/06A 34-channel single-ended probes.

Designing and Probing with Target Connections

Agilent Logic Analyzers with 90-pin Pod Connectors

E5404/06A 34-Channel Single-Ended Probe			
Signal Name	Pad #	Logic Analyzer Channel	Pod
D0	A1	→ 0	Whichever pod is connected to "Odd" on the E5404/06A probe
D1	A2	→ 1	
Ground	A3		
D4	A4	→ 4	
D5	A5	→ 5	
Ground	A6		
Clock 1+	A7	→ Clock	
GND/NC/Clock 1-	A8		
Ground	A9		
D10	A10	→ 10	
D11	A11	→ 11	
Ground	A12		
D14	A13	→ 14	
D15	A14	→ 15	
Ground	A15		
D2	A16	→ 2	
D3	A17	→ 3	
Ground	A18		
D6	A19	→ 6	
D7	A20	→ 7	
Ground	A21		
D8	A22	→ 8	
D9	A23	→ 9	
Ground	A24		
D12	A25	→ 12	
D13	A26	→ 13	
Ground	A27		

E5404/06A 34-Channel Single-Ended Probe				
Signal Name	Pad #	Logic Analyzer Channel	Pod	
Ground	B1		Whichever pod is connected to "Odd" on the E5404/06A probe	
D2	B2	→ 2		
D3	B3	→ 3		
Ground	B4			
D6	B5	→ 6		
D7	B6	→ 7		
Ground	B7			
D8	B8	→ 8		
D9	B9	→ 9		
Ground	B10			
D12	B11	→ 12		
D13	B12	→ 13		
Ground	B13			
D0	B14	→ 0		Whichever pod is connected to "Even" on the E5404/06A probe
D1	B15	→ 1		
Ground	B16			
D4	B17	→ 4		
D5	B18	→ 5		
Ground	B19			
GND/NC/Clock 2-	B20			
Clock 2+	B21	→ Clock		
Ground	B22			
D10	B23	→ 10		
D11	B24	→ 11		
Ground	B25			
D14	B26	→ 14		
D15	B27	→ 15		

Designing and Probing with Target Connections

Agilent Logic Analyzers with 90-pin Pod Connectors

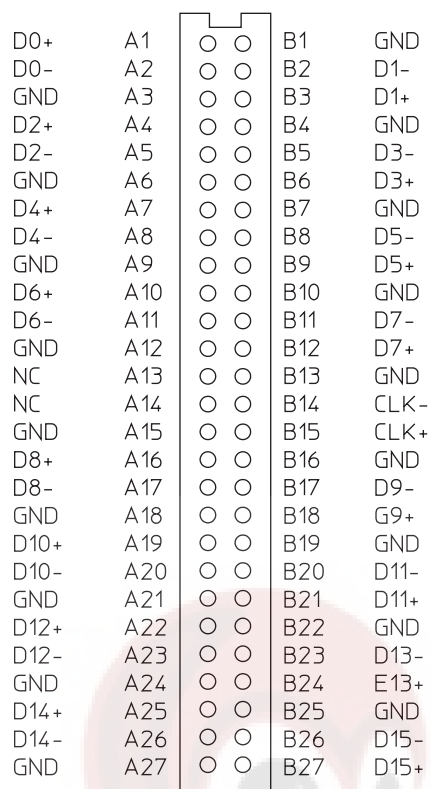


Figure 8.9. Pad numbers for E5405A 17-bit differential probe.

SG Labs
 test & measurement instruments

Designing and Probing with Target Connections

Agilent Logic Analyzers with 90-pin Pod Connectors

E5405A Differential Probe Signal Name	Pad #	Logic Analyzer Channel	Pod
D0 (+)	A1	→ 0	Whichever pod is plugged into the E5405A probe
D0 (-)	A2		
Ground	A3		
D2 (+)	A4	→ 2	
D2 (-)	A5		
Ground	A6		
D4 (+)	A7	→ 4	
D4 (-)	A8		
Ground	A9		
D6 (+)	A10	→ 6	
D6 (-)	A11		
Ground	A12		
NC	A13		
NC	A14		
Ground	A15		
D8 (+)	A16	→ 8	
D8 (-)	A17		
Ground	A18		
D10 (+)	A19	→ 10	
D10 (-)	A20		
Ground	A21		
D12 (+)	A22	→ 12	
D12 (-)	A23		
Ground	A24		
D14 (+)	A25	→ 14	
D14 (-)	A26		
Ground	A27		

E5405A Differential Probe Signal Name	Pad #	Logic Analyzer Channel	Pod
Ground	B1		Whichever pod is plugged into the E5405A probe
D1 (-)	B2		
D1 (+)	B3	→ 1	
Ground	B4		
D3 (-)	B5		
D3 (+)	B6	→ 3	
Ground	B7		
D5 (-)	B8		
D5 (+)	B9	→ 5	
Ground	B10		
D7 (-)	B11		
D7 (+)	B12	→ 7	
Ground	B13		
Clock-	B14		
Clock+	B15	→ Clock	
Ground	B16		
D9 (-)	B17		
D9 (+)	B18	→ 9	
Ground	B19		
D11 (-)	B20		
D11 (+)	B21	→ 11	
Ground	B22		
D13 (-)	B23		
D13 (+)	B24	→ 13	
Ground	B25		
D15 (-)	B26		
D15 (+)	B27	→ 15	

Designing and Probing with Target Connections

Agilent Logic Analyzers with 90-pin Pod Connectors

Probe Dimensions

The following figures show dimensions, footprint, and pinout information you will need to design your target system board for use with the Agilent soft touch probes.

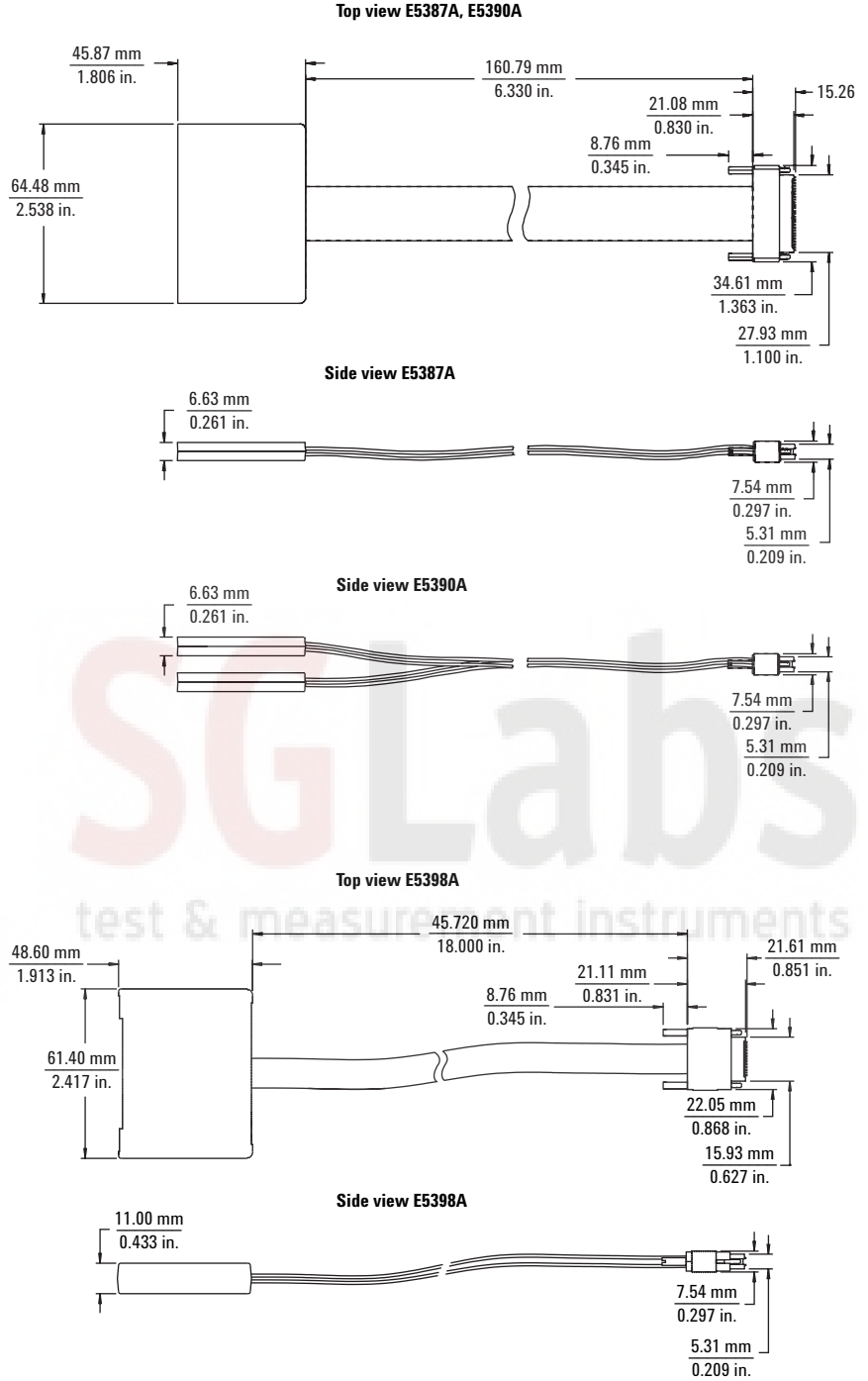


Figure 8.10. Probe dimensions

Designing and Probing with Target Connections

Agilent Logic Analyzers with 90-pin Pod Connectors

Retention Module Dimensions

The soft touch probes are attached to the PC board using a retention module which ensures pin-to-pad alignment and holds the probe in place. A board thickness of up to 2.54 mm (0.100 in.) is recommended. Insert the retention module into the board, noting the keying pin, and solder the four alignment pins to the backside of the board.

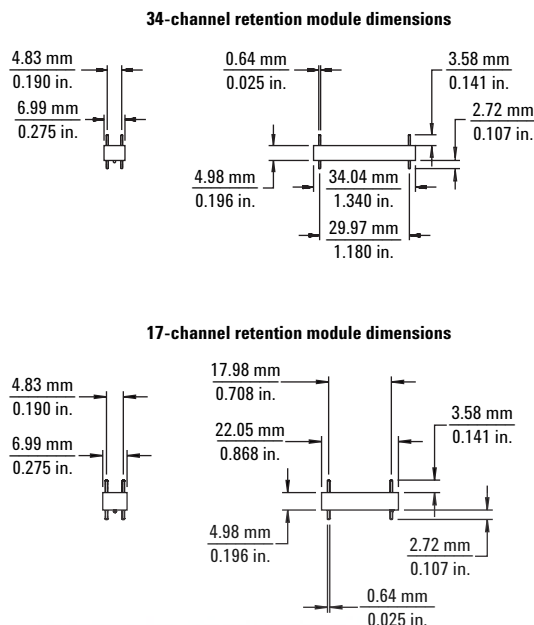


Figure 8.11. Retention module dimensions

Probe and Retention Module Dimensions

The following dimensions show the soft touch probe attached to the retention module. The retention module is mounted on the PC board.

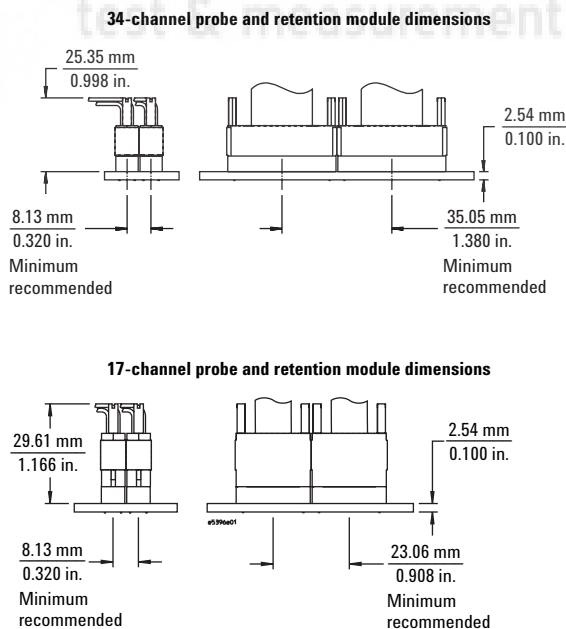


Figure 8.12. Probe and retention module dimensions

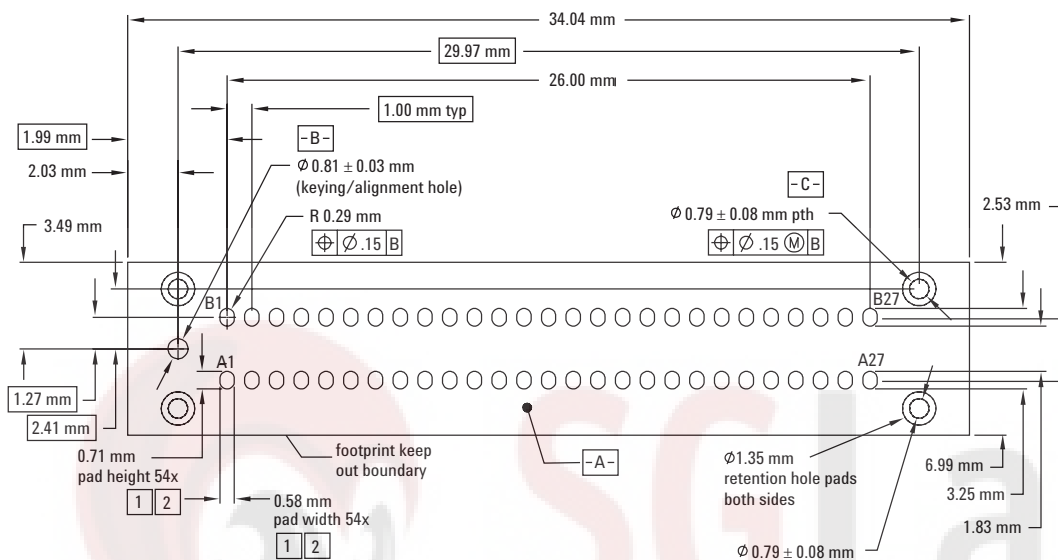
Designing and Probing with Target Connections

Agilent Logic Analyzers with 90-pin Pod Connectors

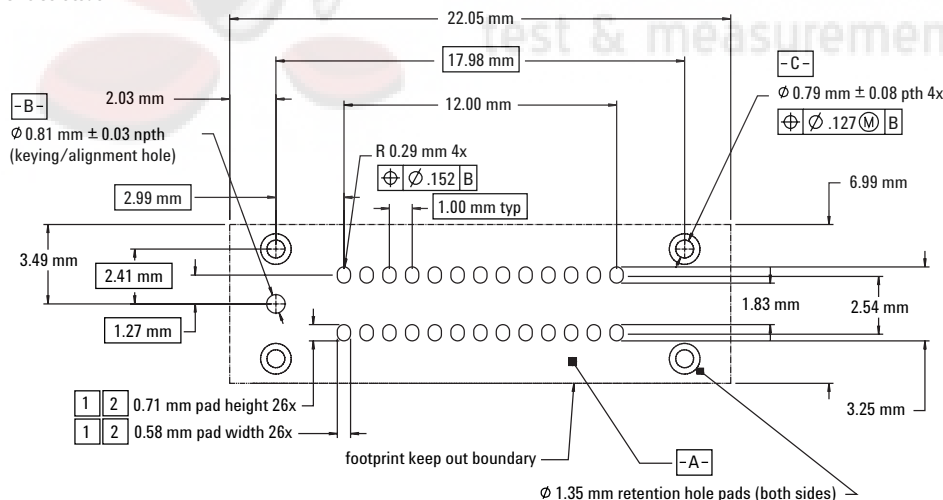
Probe Footprint Dimensions

Use these probe footprint dimensions for the PC board pads and holes for attaching the retention module.

Soft touch



Half-size soft touch



1. Must maintain a solder mask web between pads when traces are routed between the pads on the same layer. Soldermask may not encroach onto the pads within the pad dimension shown.
2. Via in pad not allowed on these pads. Via edges may be tangent to pad edges as long as a solder mask web between vias and pads is maintained.
3. Permissible surface finishes on pads are HASL, immersion silver, or gold over nickel.
4. Footprint is compatible with retention module, Agilent part # E5387-68702.
5. Retention module dimensions are 34.04 mm x 7.01 mm x 4.98 mm tall relative to the top surface of the PDB. Retention pins extend 4.32 mm beyond the bottom surface of the RM through the PCB.
6. Assume normal artwork tolerances for pad size dimensions.

Figure 8.13. Footprint dimensions

Designing and Probing with Target Connections

Agilent Logic Analyzers with 90-pin Pod Connectors

Pinout for the E5387A Differential Soft Touch Probe

The following graphic and table show the E5387A differential soft touch probe pad numbers and logic analyzer pod inputs.

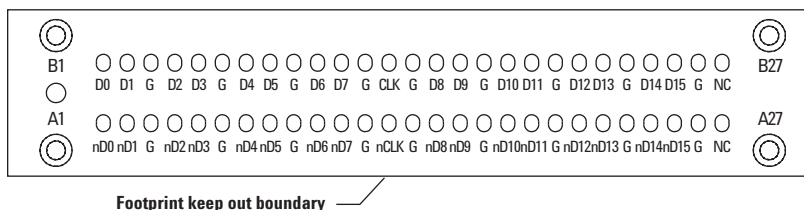


Figure 8.14. Pinout

E5387A Differential Probe

Negative Signals		Positive Signals		Logic Analyzer		
Signal Name	Pad #	Signal Name	Pad #	Channel	Pod	
D0 (-)	A1	D0 (+)	B1	→	0	Whichever pod is plugged into the E5387A probe
D1 (-)	A2	D1 (+)	B2	→	1	
Ground	A3	Ground	B3			
D2 (-)	A4	D2 (+)	B4	→	2	
D3 (-)	A5	D3 (+)	B5	→	3	
Ground	A6	Ground	B6			
D4 (-)	A7	D4 (+)	B7	→	4	
D5 (-)	A8	D5 (+)	B8	→	5	
Ground	A9	Ground	B9			
D6 (-)	A10	D6 (+)	B10	→	6	
D7 (-)	A11	D7 (+)	B11	→	7	
Ground	A12	Ground	B12			
Clock (-)	A13	Clock (+)	B13	→	Clock	
Ground	A14	Ground	B14			
D8 (-)	A15	D8 (+)	B15	→	8	
D9 (-)	A16	D9 (+)	B16	→	9	
Ground	A17	Ground	B17			
D10 (-)	A18	D10 (+)	B18	→	10	
D11 (-)	A19	D11 (+)	B19	→	11	
Ground	A20	Ground	B20			
D12 (-)	A21	D12 (+)	B21	→	12	
D13 (-)	A22	D13 (+)	B22	→	13	
Ground	A23	Ground	B23			
D14 (-)	A24	D14 (+)	B24	→	14	
D15 (-)	A25	D15 (+)	B25	→	15	
Ground	A26	Ground	B26			
N/C	A27	N/C	B27			

Designing and Probing with Target Connections

Agilent Logic Analyzers with 90-pin Pod Connectors

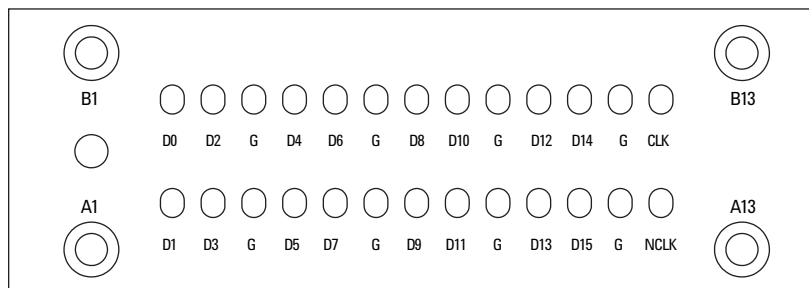


Figure 8.15. Pinout

E5398A 17-channel

Single-Ended Probe

Signal Name	Pad #		Logic Analyzer Channel	Pod
D1	A1	→	1	Whichever pod is plugged into the E5398A probe
D3	A2	→	3	
Ground	A3			
D5	A4	→	5	
D7	A5	→	7	
Ground	A6			
D9	A7	→	9	
D11	A8	→	11	
Ground	A9			
D13	A10	→	13	
D15	A11	→	15	
Ground	A12			
Clock (-)	A13	→	n/a	

E5398A 17-channel

Single-Ended Probe

Signal Name	Pad #		Logic Analyzer Channel	Pod
D0	B1	→	0	Whichever pod is plugged into the E5398A probe
D2	B2	→	2	
Ground	B3			
D4	B4	→	4	
D6	B5	→	6	
Ground	B6			
D8	B7	→	8	
D10	B8	→	10	
Ground	B9			
D12	B10	→	12	
D14	B11	→	14	
Ground	B12			
Clock (+)	B13	→	n/a	

Designing and Probing with Target Connections

Agilent Logic Analyzers with 90-pin Pod Connectors

Pinout for the E5390A Single-Ended Soft Touch Probe

The following graphic and table show the E5390A single-ended soft touch probe pad numbers and logic analyzer pod inputs.

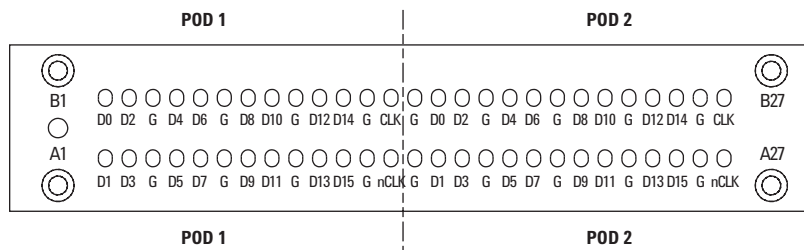


Figure 8.16. Pinout

E5390A Single-Ended Probe Signal Name	Pad #	Logic Analyzer Channel	Pod
D1	A1	→ 1	Whichever pod is connected to "Odd" on the E5390A probe
D3	A2	→ 3	
Ground	A3		
D5	A4	→ 5	
D7	A5	→ 7	
Ground	A6		
D9	A7	→ 9	
D11	A8	→ 11	
Ground	A9		
D13	A10	→ 13	
D15	A11	→ 15	
Ground	A12		
Clock (-)	A13	→ Clock	
D0	B1	→ 0	Whichever pod is connected to "Even" on the E5390A probe
D2	B2	→ 2	
Ground	B3		
D4	B4	→ 4	
D6	B5	→ 6	
Ground	B6		
D8	B7	→ 8	
D10	B8	→ 10	
Ground	B9		
D12	B10	→ 12	
D14	B11	→ 14	
Ground	B12		
Clock (+)	B13	→ Clock	

E5390A Single-Ended Probe Signal Name	Pad #	Logic Analyzer Channel	Pod
Ground	A14		Whichever pod is connected to "Even" on the E5390A probe
D1	A15	→ 1	
D3	A16	→ 3	
Ground	A17		
D5	A18	→ 5	
D7	A19	→ 7	
Ground	A20		
D9	A21	→ 9	
D11	A22	→ 11	
Ground	A23		
D13	A24	→ 13	
D15	A25	→ 15	
Ground	A26		
Clock (-)	A27	→ Clock	
Ground	B14		Whichever pod is connected to "Odd" on the E5390A probe
D0	B15	→ 0	
D2	B16	→ 2	
Ground	B17		
D4	B18	→ 4	
D6	B19	→ 6	
Ground	B20		
D8	B21	→ 8	
D10	B22	→ 10	
Ground	B23		
D12	B24	→ 12	
D14	B25	→ 14	
Ground	B26		
Clock (+)	B27	→ Clock	

Designing and Probing with Target Connections

Agilent Logic Analyzers with 90-pin Pod Connectors

Equivalent Probe Loads

The following probe load models are based on in-circuit measurements made with an Agilent 8753E 6 GHz network analyzer and an Agilent 54750A TDR/TDT using a 50 Ω test fixture. The following schematic accurately models the probe load out to 6 GHz. PC board pads are not included.

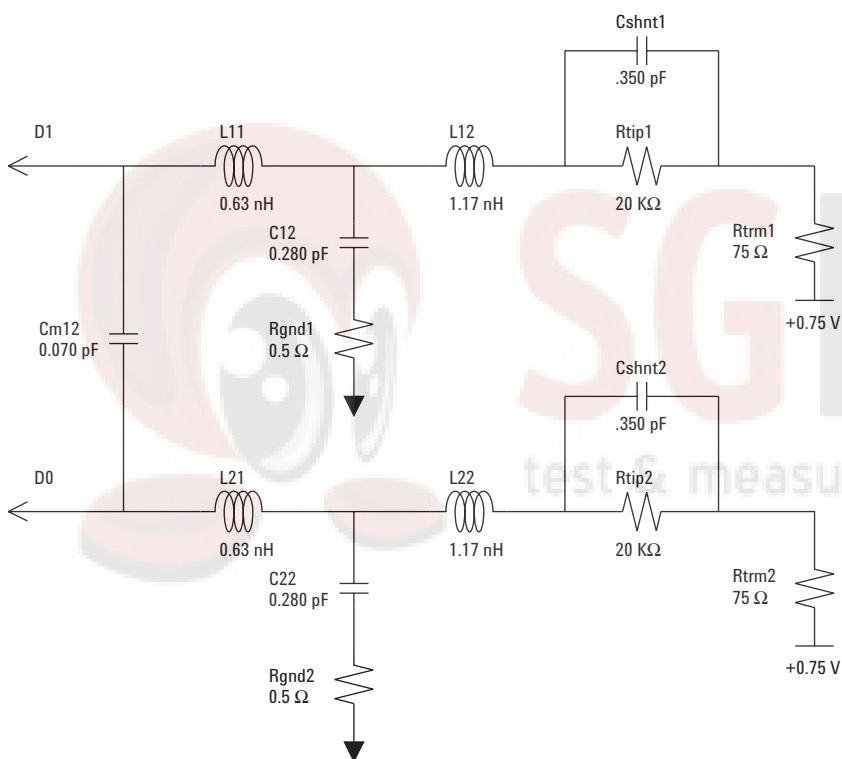


Figure 8.17. Equivalent probe load model

Designing and Probing with Target Connections

Agilent Logic Analyzers with 90-pin Pod Connectors

E5378A 100-Pin Single-Ended Probe

The E5378A is a 34-channel single-ended probe capable of capturing data up to 1.5 Gbits/sec (see Figures 10.3 and 10.5 for probe dimensions and equivalent load). The probe has the following inputs:

- 32 single-ended data inputs, in two groups (pods) of 16.
- Two differential clock inputs. Either or both clock inputs can be acquired as data inputs if not used as a clock.
- Two data threshold reference inputs, one for each pod (group of 16 data inputs).

E5379A 100-Pin Differential Probe

The E5379A is a 17-channel differential probe capable of capturing data up to 1.5 Gbits/sec (see Figures 10.5 and 10.6 for probe dimensions and equivalent load). The probe has the following inputs:

- 16 differential data inputs.
- One differential clock input. The clock input can be acquired as a data input if it is not used as a clock.

Refer to Table 9 on page 59 for part numbers for mating connectors and shrouds.

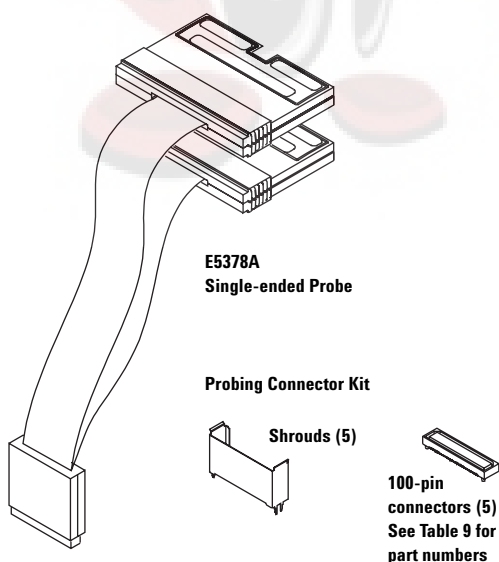


Figure 8.18. Agilent E5378A probe

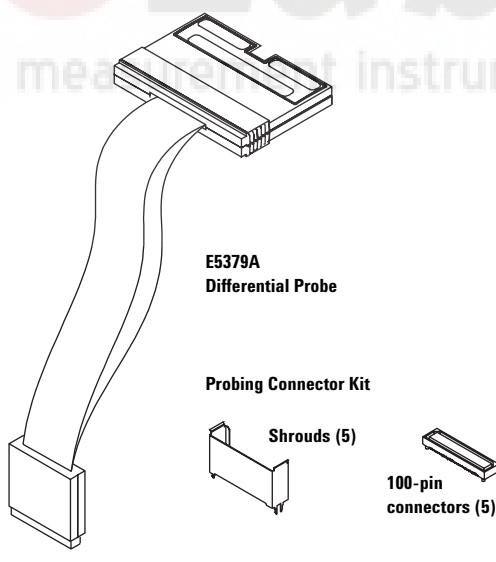


Figure 8.19. Agilent E5379A probe

Designing and Probing with Target Connections

Agilent 16760A 1.5 Gbits/Sec Logic Analyzer Module

E5386A Half-Channel Adapter

When the Agilent 16760A is operated in the 1250 Mb/s or 1500 Mb/s mode, only the even numbered channels are used. To reduce the number of probes and connectors required, the E5386A adapter maps the even channels to all of the pins of an E5378A, E5379A, E5387A, E5390A, E5405A, or E5406A probe. The E5386A half-channel adapter is usable with either the E5378A, E5390A, or E5406A single-ended probe or the E5379A, E5387A, or E5405A differential probe. The following diagrams show how the E5386A is connected.



Figure 9.1. E5386A half-channel probe adapter

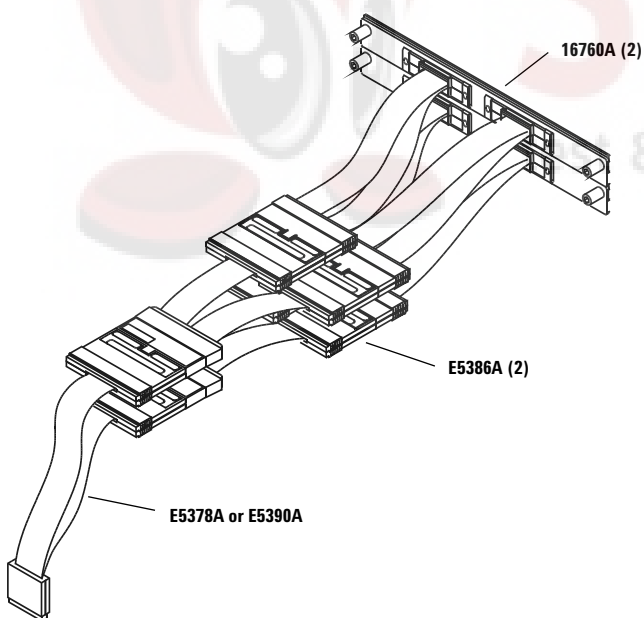


Figure 9.2. E5386A with E5378A, E5390A, or E5406A single-ended probe

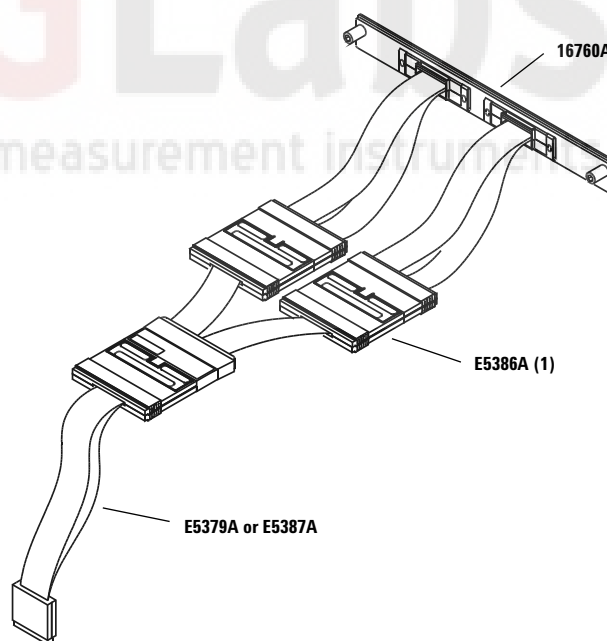


Figure 9.3. E5386A with E5379A, E5387A, or E5405A differential probe

Designing and Probing with Target Connections

Agilent Logic Analyzers with 90-pin Pod Connectors

E5380A 38-Pin Probe

The E5380A is designed to be compatible with the Mictor connector. If you have a target system designed for connection to the E5346A high-density probe adapter, the E5380A probe will connect directly to this same Mictor connector. (For information on the E5346A, refer to pages 28-29). The maximum state speed when used with the E5380A probe is 600 Mb/s. The minimum input signal amplitude required by the E5380A is 300 mV.

The E5380A probe combines two 17-channel cables into a single-ended 38-pin Mictor connector.

Refer to Table 9 for connector, shroud, and kit part numbers.

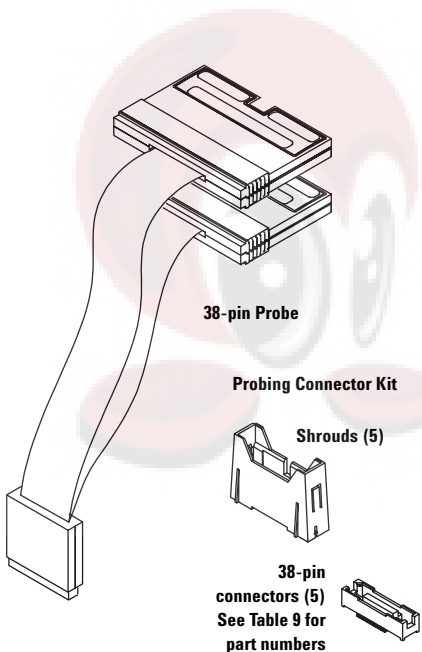


Figure 10.1. Agilent E5380A probe

For probe model numbers	Description	Agilent part number
E5378A, E5379A	Kit of 5 support shrouds and 5 100-pin Samtec connectors for PC board thickness up to 1.57 mm (0.062")	16760-68702
	Kit of 5 support shrouds and 5 100-pin Samtec connectors for PC board thickness up to 3.05 mm (0.120")	16760-68703
	One 100-pin Samtec connector (also available from Samtec as part number ASP-65067-01)	1253-3620
	One support shroud for PC board thickness up to 1.57 mm (0.062")	16760-02302
	One support shroud for PC board thickness up to 3.05 mm (0.120")	16760-02303
E5380A	Kit of 5 support shrouds and 5 38-pin Mictor connectors for PC board thickness up to 1.57 mm (0.062")	E5346-68701
	Kit of 5 support shrouds and 5 38-pin Mictor connectors for PC board thickness up to 3.175 mm (0.125")	E5346-68700
	One 38-pin Mictor connector (also available from AMP as part number 2-767004-2)	1252-7431
	One support shroud for PC board thickness up to 1.57 mm (0.062")	E5346-44701
	One support shroud for PC board thickness up to 3.175 mm (0.125")	E4346-44704
	One support shroud for PC board thickness up to 4.318 mm (0.700")	E5346-44703

Table 9. Mating connectors, shrouds, and kits for Agilent E5378A, E5379A, and E5380A probes

For further information on designing the E5378A, E5379A, or E5380A probe connectors into your system, refer to the following documents:

Agilent Technologies Logic Analyzer Probes (E5378A, E5379A, E5380A, and E5386A) User's Guide	Mechanical drawings, electrical models, general information on probes for logic analyzers with 90-pin connectors	16760-97008	http://cp.literature.agilent.com/litweb/pdf/16760-97008.pdf
Designing High-Speed Digital Systems for Logic Analyzer Probing	Design recommendations, examples, and analysis for layout of target systems	5988-2989EN	http://www.agilent.com/find/probeguide

Designing and Probing with Target Connections

Agilent Logic Analyzers with 90-pin Pod Connectors

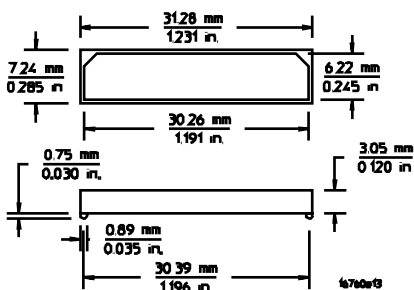


Figure 10.2. Dimensions of the 100-Pin Samtec connector used in the 16760-68702 and 16760-68703 connector kits

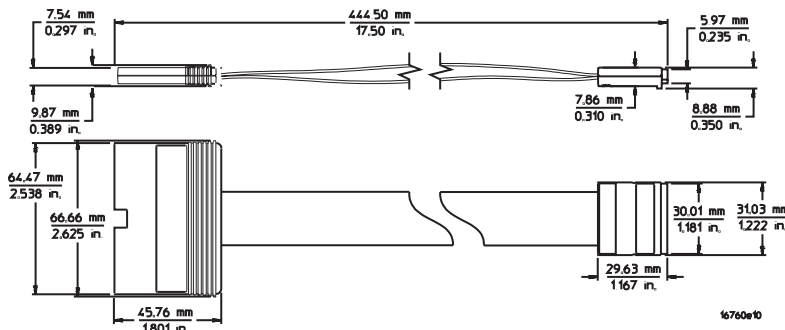


Figure 10.3. E5378A 100-pin single-ended probe dimensions

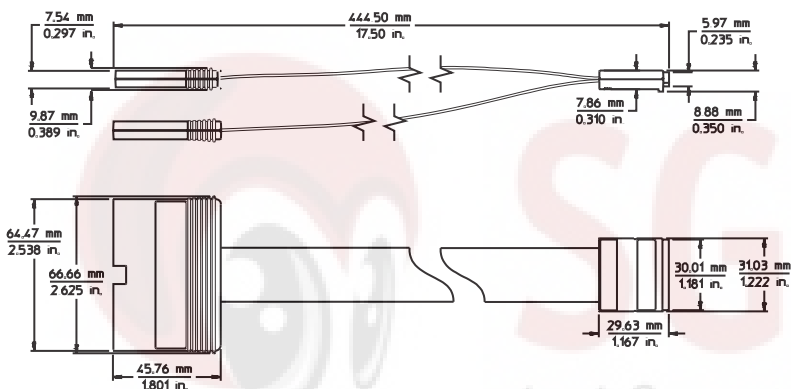


Figure 10.4. E5379A 100-pin differential probe dimensions

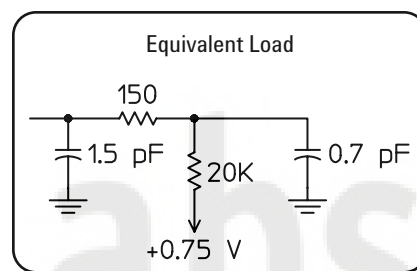


Figure 10.5. E5378A and E5379A input equivalent load, including 100-pin connector

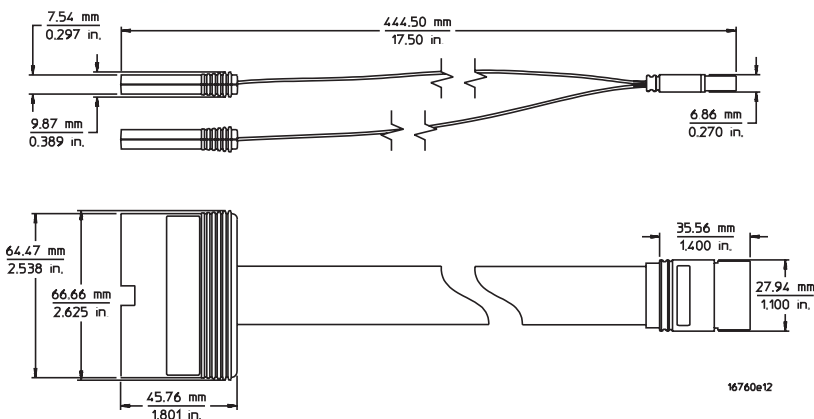


Figure 10.6. E5380A 38-Pin probe dimensions

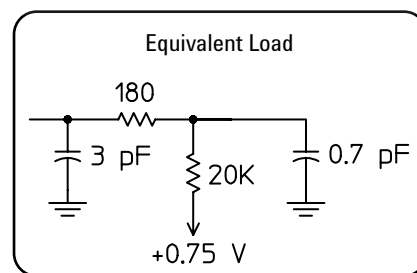


Figure 10.7. E5380A input equivalent load, including 38-pin connector

General-Purpose Probing

Agilent Logic Analyzers with 90-pin Pod Connectors

E5382A Single-Ended Flying Lead Probe Set

The E5382A is a 17-channel single-ended flying lead probe compatible with logic analyzers with a 90-pin pod connection. It is capable of acquiring data at the maximum rates of the logic analyzer it is connected to. The E5382A is useful for acquiring signals from dispersed locations or when a mass connection scheme is not available. The E5382A has the following:

- 16 single-ended data inputs
- one differential or single-ended clock input
- variety of supplied accessories

Unused clock inputs can be used as data inputs.


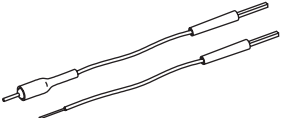
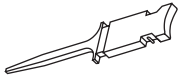

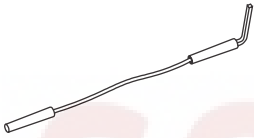
	Part number	Description
	E5382-82102	Probe pin kit, 2 resistive pins per kit
	E5382-82101	High-frequency probing kit, 2 resistive signal wires and 4 ground wires per kit
	16517-82109	Grabber clip kit, 20 grabbers per kit
	16517-82105	Ground extender kit, 20 ground extenders per kit
	16517-82106	Right-angle ground lead kit, 20 ground leads per kit

Table 10. Accessories.

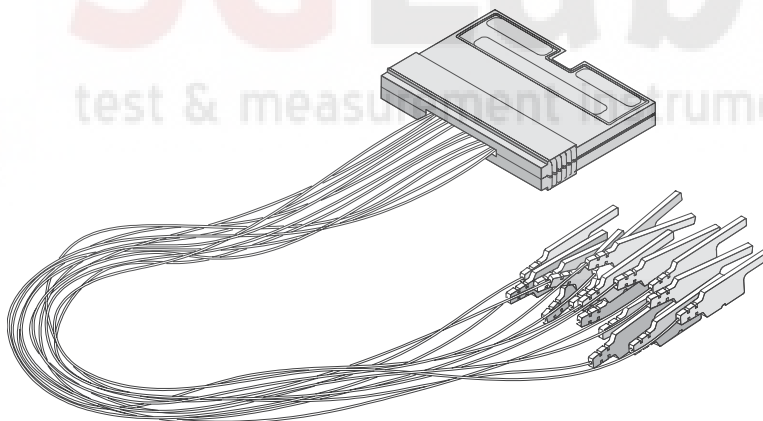


Figure 11.1. E5382A flying lead set

General-Purpose Probing

Agilent Logic Analyzers with 90-pin Pod Connectors

Suggested Configurations and Characteristics

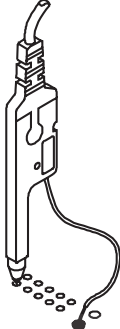
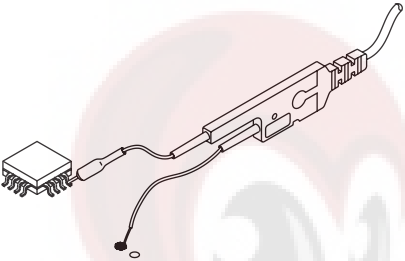
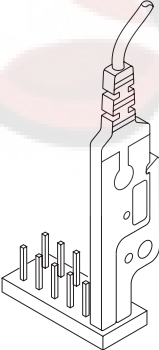
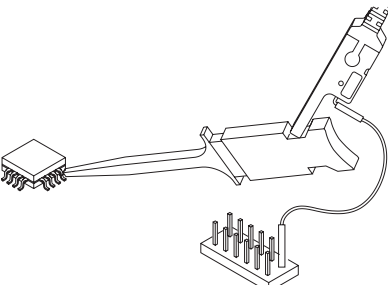
Configuration	Description	Total Lumped Input C	Maximum Recommended State Speed
	130 Ω Resistive Signal Pin (orange) and Solder-down Ground Lead	1.3 pF	1.5 Gb/s
	5 cm Resistive Signal Lead (can be Soldered-down) and Solder-down Ground Lead	1.6 pF	1.5 Gb/s
	Flying Lead and Ground Extender	1.4 pF	1.5 Gb/s
	Grabber Clip and Right-angle 2.0 pF Ground Lead	2.0 pF	600 Mb/s

Table 11. E5382A suggested configurations and characteristics

General-Purpose Probing

Agilent Logic Analyzers with 90-pin Pod Connectors

Available Accessories

Ground Connector

It is essential to ground every tip that is in use. For best performance at high speeds, every tip should be grounded individually to ground in the system under test. For convenience in connecting grounds, you can use the ground connector, Agilent part number 16515-27601, to combine up to four probe tip grounds to connect to one ground point in the system under test.

Adapting to Coaxial Connectors

The Agilent E9638A probe tip to BNC adapter can be used to connect one of the flying lead probes of the E5382A to a BNC connector. To probe other coaxial connectors, use the E9638A adapter, a BNC termination, and an adapter to the other type of coaxial connector. Refer to Figure 11.3.

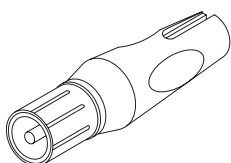


Figure 11.2. E9638A BNC to probe tip adapter

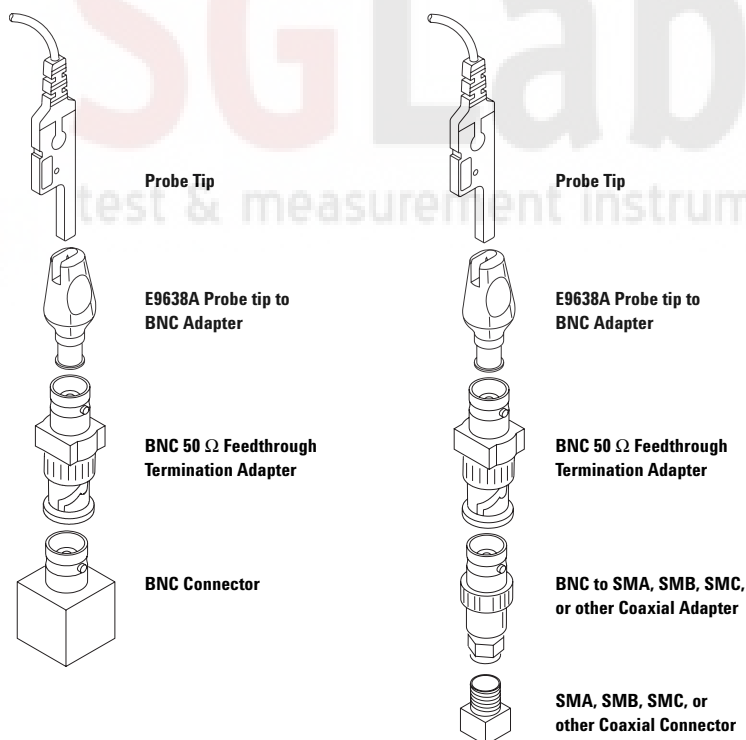
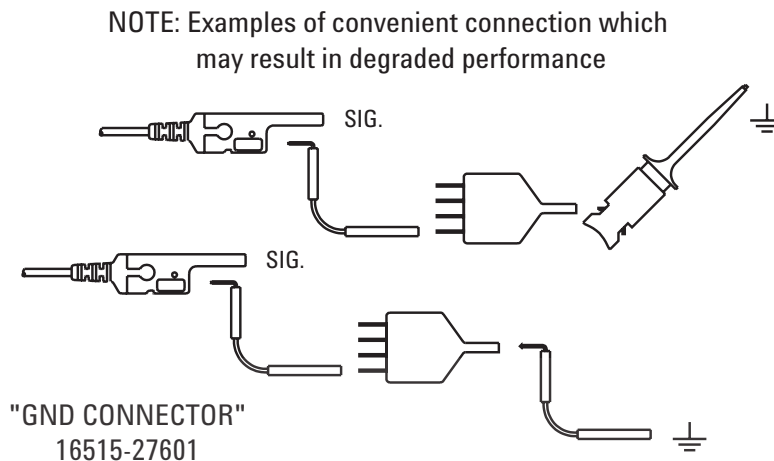


Figure 11.3. Recommended configurations to probe RF coaxial connectors with the E5382A flying lead probes

General-Purpose Probing

Agilent Logic Analyzers with 90-pin Pod Connectors

E5381A Differential Flying-Lead Probe Set

The E5381A is a 17-channel differential flying-lead probe compatible with logic analyzers with a 90-pin pod connection. It is capable of acquiring data at the maximum rates of the logic analyzer it is connected to. The E5381A is useful for acquiring signals from dispersed locations or when a mass connection scheme is not available. The E5381A has the following:

- 16 differential or single-ended data inputs
- one differential or single-ended clock input
- variety of supplied accessories

Unused clock inputs can be used as data inputs.

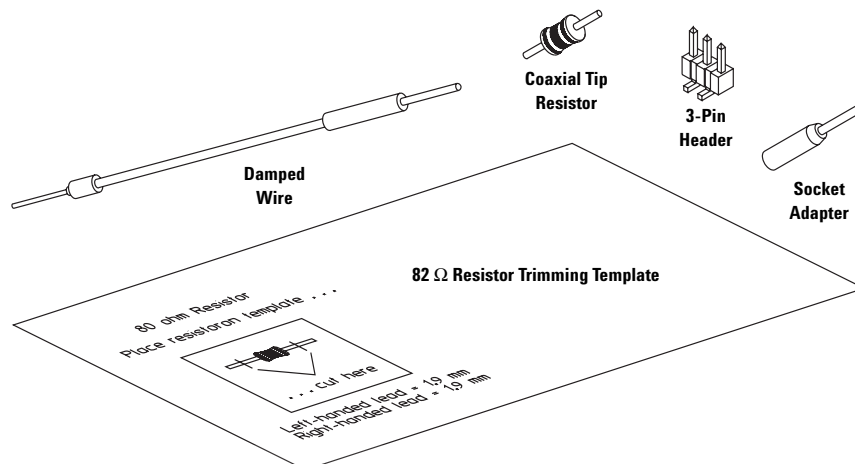


Figure 11.4. E5381A differential flying-lead probe set accessories

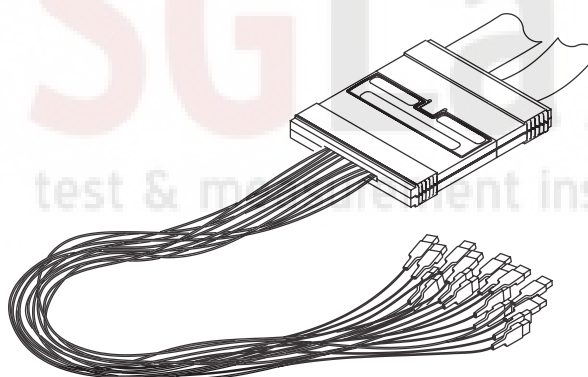


Figure 11.5. E5381A differential flying-lead probe set

General-Purpose Probing

Agilent Logic Analyzers with 90-pin Pod Connectors

Suggested Configurations and Characteristics

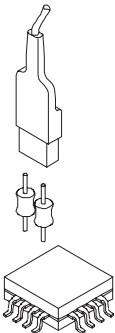
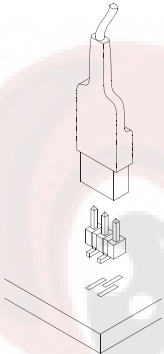
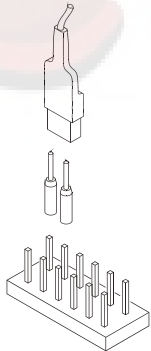
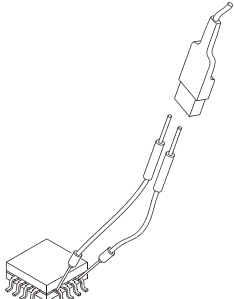
Configuration	Description	Total Lumped Input C	Maximum Recommended State Speed
	Coaxial Tip Resistor (82 Ω blue) Solder Attach to Components, Traces, Pads, or VIAs.	0.9 pF	1.5 Gb/s
	3-pin Header	1.0 pF	1.5 Gb/s
	Socket Adapter	1.1 pF	1.5 Gb/s
	Damped Wire Solder Attach to Components, Traces, Pads, or VIAs.	1.3 pF	1.5 Gb/s

Table 12. E5381A suggested configurations and characteristics

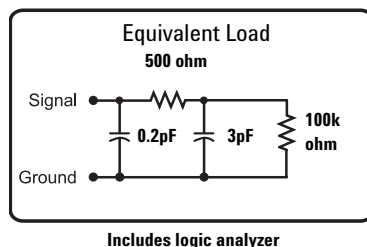
Agilent 16517A/16518A 1 GHz State / 4 GHz Timing

High-Speed Logic Analysis General-Purpose Probes

The Agilent 16517A and 16518A logic analysis modules were discontinued in April 2002. Probing accessories for these modules are listed here for convenience in ordering additional accessories if needed.

Special Connectors

The Agilent 16517A/16518A can conveniently probe an SMA or BNC connector with the adapters shown in Figures 12.3 and 12.4. The flexible ground pin, Figure 12.2, provides excellent signal fidelity when used as shown in Figure 12.6.



Includes logic analyzer

Figure 12.1. Equivalent load for high-speed general-purpose probe



Figure 12.2. E5320-26101 flexible ground pin

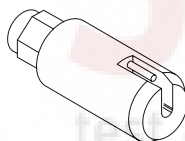


Figure 12.3. 16517-27601 SMA adapter

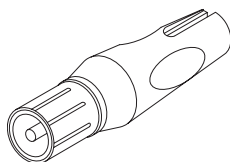


Figure 12.4. E9638A Probe tip to BNC adapter

Agilent 16517A/16518A 1 GHz State / 4 GHz Timing

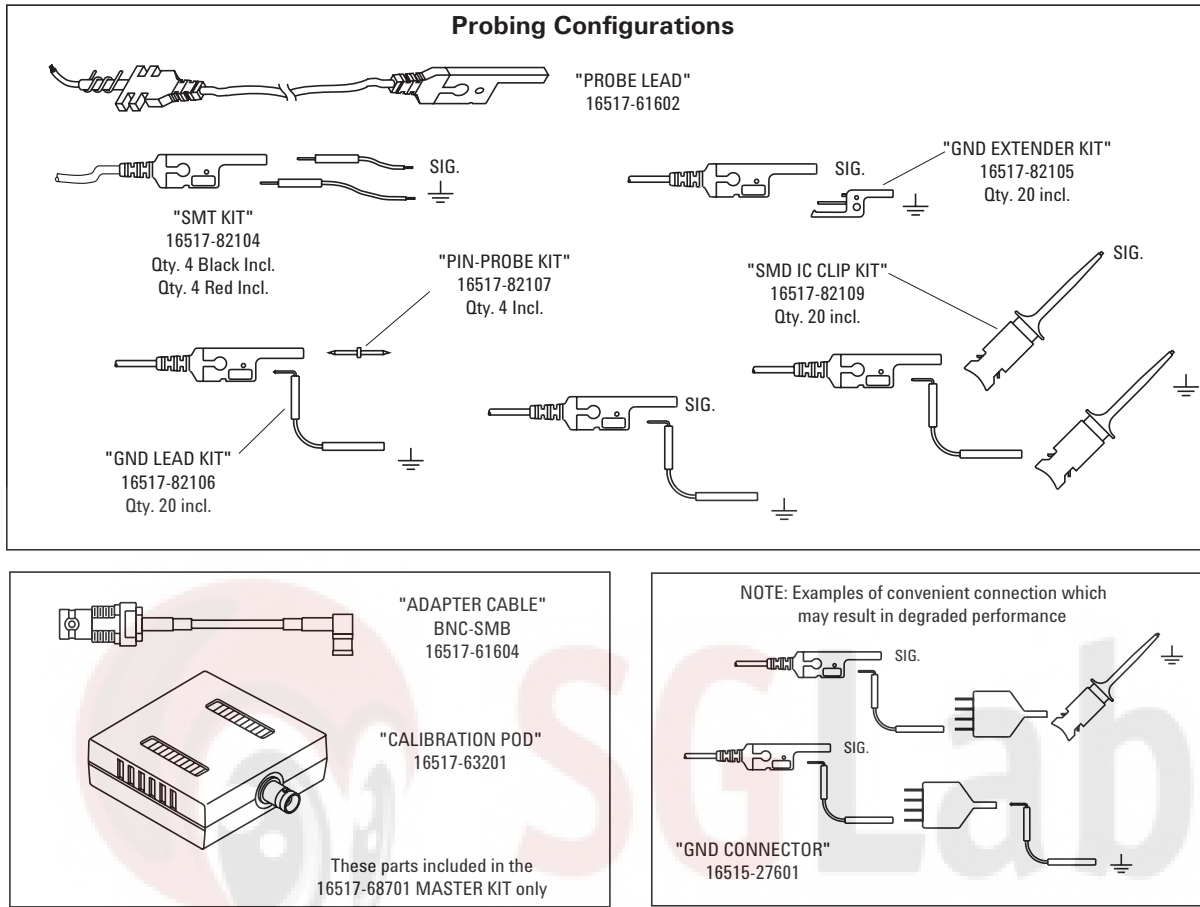


Figure 12.5. Agilent Technologies 16517-68701 master accessory kit and 16518-68701 expansion accessory kit

Recommended Probe Configurations

For the best performance, use the following configurations. The configurations are listed in the recommended order.

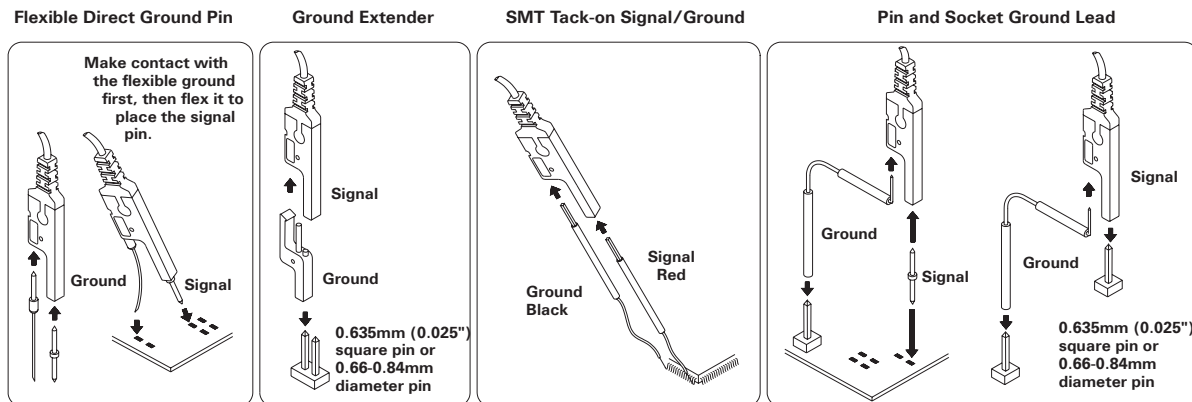


Figure 12.6. Probing configurations that give the best signal fidelity

Related Information

Agilent Technologies logic analysis third-party partners:

For a complete list of partners, see document 5966-4365EUS "Processor and Bus Support for Agilent Technologies Logic Analyzers."

3M

<http://www.mmm.com/interconnects>

AMP, Inc.

Phone: 1-717-986-7777

Fax: 1-717-986-7575

Phone (USA only): 1-800-522-6752

E-mail: product.info@amp.com

Web site: <http://www.amp.com>

Agilent Technologies Test and Measurement Organization support line phone number:
1-800-452-4844

Agilent Technologies Test and Measurement Organization web site:
<http://www.agilent.com>

Agilent Technologies Test and Measurement Logic Analyzers web site:

<http://www.agilent.com/find/logic>

Agilent Technologies Test and Measurement Processor and Bus Support web site:

<http://www.agilent.com/find/PnBS>

Agilent Technologies Test and Measurements Accessories web site:
<http://www.agilent.com/find/LAccessories>

For custom probing accessories not listed in this document, Agilent recommends that you contact:

JM Engineering

3502 E. Boulder

Colorado Springs, CO 80909

Phone: 1-719-591-1119

Web site: <http://www.jmecorp.com>

This document does not cover the following topics:

- Pattern generator probing and accessories

See: *Agilent Technologies 16700 Series Logic Analysis System, Product Overview*, publication number 5968-9661E

- Analysis probes for processors and buses

See: *Processor and Bus Support for Agilent Technologies Logic Analyzers, Configuration Guide*, publication number 5966-4365E



www.agilent.com

Agilent Technologies' Test and Measurement Support, Services, and Assistance

Agilent Technologies aims to maximize the value you receive, while minimizing your risk and problems. We strive to ensure that you get the test and measurement capabilities you paid for and obtain the support you need. Our extensive support resources and services can help you choose the right Agilent products for your applications and apply them successfully. Every instrument and system we sell has a global warranty. Two concepts underlie Agilent's overall support policy: "Our Promise" and "Your Advantage."

Our Promise

Our Promise means your Agilent test and measurement equipment will meet its advertised performance and functionality. When you are choosing new equipment, we will help you with product information, including realistic performance specifications and practical recommendations from experienced test engineers. When you receive your new Agilent equipment, we can help verify that it works properly and help with initial product operation.

Your Advantage

Your Advantage means that Agilent offers a wide range of additional expert test and measurement services, which you can purchase according to your unique technical and business needs. Solve problems efficiently and gain a competitive edge by contracting with us for calibration, extra-cost upgrades, out-of-warranty repairs, and onsite education and training, as well as design, system integration, project management, and other professional engineering services. Experienced Agilent engineers and technicians worldwide can help you maximize your productivity, optimize the return on investment of your Agilent instruments and systems, and obtain dependable measurement accuracy for the life of those products.

www.agilent.com/find/emailupdates

Get the latest information on the products and applications you select.



Agilent Email Updates

Agilent T&M Software and Connectivity

Agilent's Test and Measurement software and connectivity products, solutions and developer network allows you to take time out of connecting your instruments to your computer with tools based on PC standards, so you can focus on your tasks, not on your connections. Visit

www.agilent.com/find/connectivity
for more information.

For more information on Agilent Technologies' products, applications or services, please contact your local Agilent office. The complete list is available at:

www.agilent.com/find/contactus

Phone or Fax

United States:

(tel) 800 829 4444

(fax) 800 829 4433

Canada:

(tel) 877 894 4414

(fax) 800 746 4866

China:

(tel) 800 810 0189

(fax) 800 820 2816

Europe:

(tel) 31 20 547 2111

Japan:

(tel) (81) 426 56 7832

(fax) (81) 426 56 7840

Korea:

(tel) (080) 769 0800

(fax) (080)769 0900

Latin America:

(tel) (305) 269 7500

Taiwan:

(tel) 0800 047 866

(fax) 0800 286 331

Other Asia Pacific Countries:

(tel) (65) 6375 8100

(fax) (65) 6755 0042

Email: tm_ap@agilent.com

Contacts revised: 04/25/05

Product specifications and descriptions in this document subject to change without notice.

© Agilent Technologies, Inc. 2005

Printed in USA, April 26, 2005

5968-4632E



www.agilent.com/find/agilentdirect

Quickly choose and use your test equipment solutions with confidence.



Agilent Technologies